

Non Contact Seals Type CF



GMN Non Contact Seals

- for spindle bearings: Type CF 60/619
- for deep groove ball bearings: Type CF 62





GMN

GMN Non Contact Seals

The specific design of GMN Non Contact Seals allows operation without any friction. Many different applications, especially high-speed applications, are taking advantage of this major benefit.

The seals are running maintenance free and without any wear with unlimited lifetime. As a result of no friction there is no power loss and no generation of heat and so the seal provides an optimum of efficiency.

GMN Type CF

Non Contact Seals Type CF are specifically designed for spindle bearings and offer highest efficiency with absolutely leak tightness within a minimized space of 6 mm width only.

The labyrinth design is a combination of gaps in axial and radial direction in five steps. The axial gaps are shielding while the radial gaps are providing back transport. A catching groove improves the sealing efficiency – even without any shaft rotation.

The option of saving sealing air and increased maintenance intervals are offering a considerable commercial progress and advantage.

Non Contact Seals for spindle bearings

GMN Type CF 60/619

GMN Non Contact Seals Type CF 60 and CF 619 are produced according to the dimensions of ball bearing rows 60 and 619. They are made of nitriding steel, hardened and face-ground. The spindle bearing is pre-loaded directly through the CF seal's inner ring.

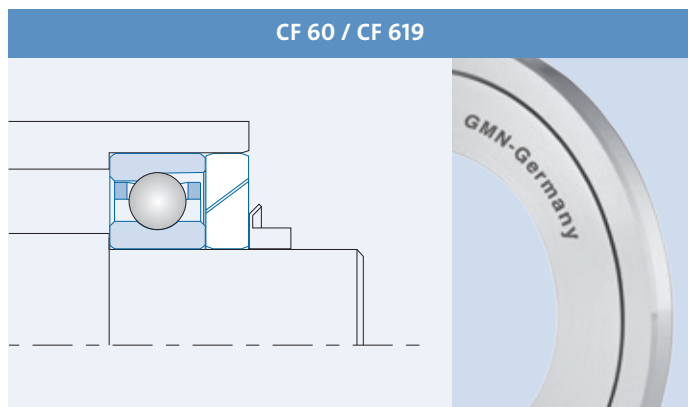

Technical data

Material: Steel

Hardness: HRC = 45

Plane-parallelism: $\leq 5 \mu\text{m}$

Range of temperature: $-40^{\circ}\text{C} - 170^{\circ}\text{C}$

Speed limit: No limit

CF 60 and CF 619 are positioned between the spindle bearing and the shaft nut without any axial mobility. For this reason there is no speed limit in this specific adjustment.

Design: Main dimensions (shaft/hub) according to ball bearing row 60 and row 619

Series 60 diameter: 20–100 mm

Series 619 diameter: 40–80 mm

Width: 6 mm for all sizes

Sealing gap: CF-Profile

Axial clearance: $S_{ax} = 1 \text{ mm}$
(Total axial movement)

Radial clearance: $S_{rad} = 0,5 \text{ mm}$
(Total radial movement)

Characteristics

Material:

- To be used in a wide range of temperature
Nitriding steel is used for operating temperatures up to $170^{\circ}\text{C} / 338^{\circ}\text{F}$
- Resistant
The hardened material is resistant against abrasive particles and chips

Design:

- No friction
Non-contact design of inner ring and outer ring
- No wear
Unlimited operating life time
- No abrasion
Fulfill highest requirements in cleanliness
- Unlimited speed
No axial movement between spindle bearing and shaft nut
- No increased temperatures
No thermal effects to the seal and the surrounding components
- Power saving performance
Non-friction operation with no loss of power which meets highest ecological and economical demands
- Compact design
Small width of 6 mm for all diameters allows a space saving solution
- Efficiency
High sealing efficiency against heavy splashing liquids in a wide range of speeds – even without any rotation
- Easy to assemble
No modification of the mating parts (different diameter or tolerances, hardening, shaft shoulder)
Easy assembly directly in contact with the spindle bearing

Non Contact Seals for deep groove ball bearings

GMN Type CF 62

For an effective sealing of standard deep groove ball bearings GMN Non Contact Seals Type CF 62 are produced in aluminum with non-ground plane surfaces, dimensions according to ball bearing row 62.

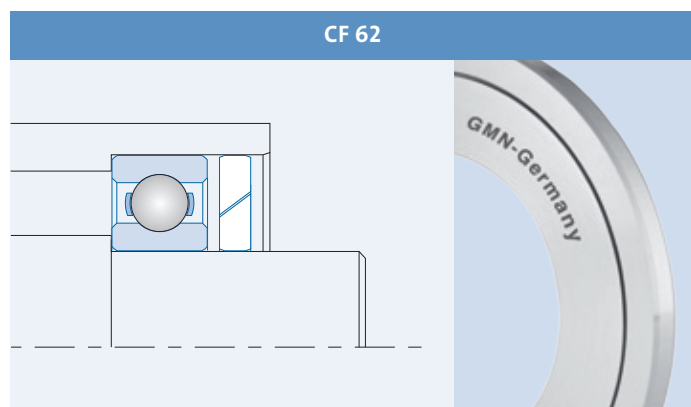

Technical data

Material: Aluminum

Range of temperature: -40°C – 200°C

Design: Main dimensions (shaft/hub) according to ball bearing row 62

Diameter: 10–50 mm

Width: 6 mm for all sizes

Sealing gap: CF-Profile

Axial clearance: $S_{ax} = 1 \text{ mm}$
(Total axial movement)

Radial clearance: $S_{rad} = 0,5 \text{ mm}$
(Total radial movement)

Mating parts: Shaft tolerance k5 / housing tolerance J6

Characteristics

Material:

- To be used in a wide range of temperature
Aluminum is used for operating temperatures up to 200° C / 392°F
- Well suited for high speed applications
Low mass of the inner ring when shaft is rotating

Design:

- No friction
Non-contact design of inner ring and outer ring
- No wear
Unlimited operating life time
- No abrasion
Fulfill highest requirements in cleanliness
- No increased temperatures
No thermal effects to the seal and the surrounding components
- Power saving performance
Non-friction operation with no loss of power which meets highest ecological and economical demands
- Compact design
Small width of 6 mm for all diameters allows a space saving solution
- Efficiency
High sealing efficiency against heavy splashing liquids in a wide range of speeds – even without any rotation
- Easy to assemble
No modification of the mating parts (different diameter or tolerances, hardening, shaft shoulder)

Type CF 60

Part name	ID [mm]	OD [mm]	W [mm]	e ₁ [mm]	e ₂ [mm]	n _{max.} [rpm]	Weight [kg]	Item no.
CF 6004	20	42	6	28	38	-	0.051	306831
CF 6005	25	47	6	33	43	-	0.059	306835
CF 6006	30	55	6	39	49	-	0.079	306839
CF 6007	35	62	6	45	55	-	0.097	306843
CF 6008	40	68	6	50	60	-	0.113	306847
CF 6009	45	75	6	55	65	-	0.134	306851
CF 6010	50	80	6	60	70	-	0.145	306855
CF 6011	55	90	6	67	77	-	0.189	306859
CF 6012	60	95	6	72	82	-	0.202	306863
CF 6013	65	100	6	77	87	-	0.215	306867
CF 6014	70	110	6	83	93	-	0.268	306871
CF 6015	75	115	6	89	99	-	0.283	306875
CF 6016	80	125	6	94	104	-	0.343	306879
CF 6017	85	130	6	100	110	-	0.360	306883
CF 6018	90	140	6	107	117	-	0.428	306887
CF 6019	95	145	6	112	122	-	0.447	306891
CF 6020	100	150	6	117	127	-	0.465	306895

Type CF 619

CF 61908	40	62	6	48	58	-	0.084	306899
CF 61909	45	68	6	53	63	-	0.097	306903
CF 61910	50	72	6	58	68	-	0.100	306907
CF 61911	55	80	6	63	73	-	0.126	306911
CF 61912	60	85	6	68	78	-	0.135	306915
CF 61913	65	90	6	73	83	-	0.144	306919
CF 61914	70	100	6	80	90	-	0.190	306923
CF 61915	75	105	6	85	95	-	0.201	306927
CF 61916	80	110	6	90	100	-	0.212	306931

Type CF 62

Part name	ID [mm]	OD [mm]	W [mm]	e ₁ [mm]	e ₂ [mm]	n _{max.} [rpm]	Weight [kg]	Item no.
CF 6200	10	30	6	17	27	66,420	0.010	306787
CF 6201	12	32	6	19	29	54,330	0.011	306791
CF 6202	15	35	6	22	32	46,100	0.013	306795
CF 6203	17	40	6	25	35	50,200	0.017	306799
CF 6204	20	47	6	29	39	45,580	0.023	306803
CF 6205	25	52	6	34	44	36,570	0.026	306807
CF 6206	30	62	6	42	52	32,270	0.037	306811
CF 6207	35	72	6	48	58	28,090	0.050	306815
CF 6208	40	80	6	54	64	24,810	0.061	306819
CF 6209	45	85	6	58	68	21,980	0.066	306823
CF 6210	50	90	6	63	73	19,810	0.071	306827

Installation: Type CF

Inner ring and outer ring of the seal are pressed-in with an assembling aid together at the same time. So both rings are axially aligned without any contact to each other.

The bigger gap diameter (e₂) must always face the splashing contamination.

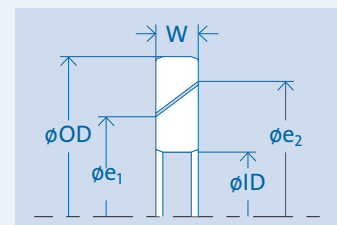
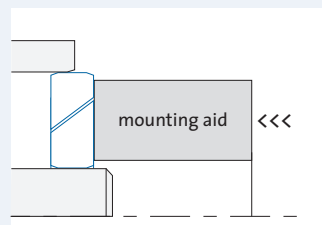



GMN

High Precision Ball Bearings
Spindle Technology
Sprag Type Freewheel Clutches
Non Contact Seals

GMN Paul Müller Industrie GmbH & Co. KG

Äußere Bayreuther Str. 230 · D-90411 Nuremberg

Phone: +49 911-5691-0 · Fax: +49 911-5691-221

www.gmn.de

Non Contact Seals:

Phone: +49 (0) 911-56 91-279 · Fax: +49 911-5691-569

Mail: vertrieb.at@gmn.de

Official GMN Representative:

