

GMN Paul Müller Industrie GmbH & Co. KG
Äußere Bayreuther Str. 230 · D-90411 Nürnberg
Phone: +49 911-5691-0 · Fax: +49 911-5691-221
Mail: info@gmn.de
www.gmn.de

Spindle technology:
Phone: +49 911-5691-576 · Fax: +49 911-5691-699
Mail: vertrieb.spi@gmn.de

Official GMN Representative:

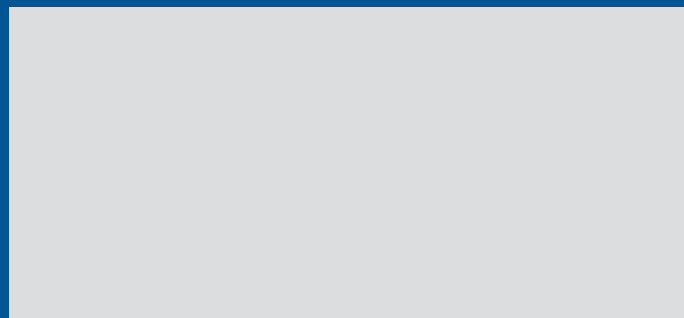

Oil/Air Lubricator PRELUB GP

Oil/Air Lubricator PRELUB GP

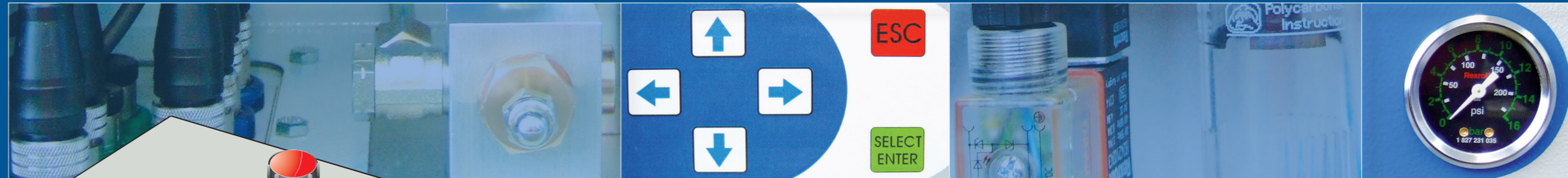

The oil-air lubricator PRELUB GP is matched optimally to the application for GMN machine spindles.

After a pre-lubrication cycle to be defined once, the device switches automatically into the normal lubrication cycle. Thus it is guaranteed that the high-precision ball bearings are supplied with sufficient oil right from the start before the spindles are released for operation. The optical filling level monitoring of the lubricant container is an appropriate way to ensure the continuous oil supply of the bearings during the operation.

Up to four lubricating points and thus two spindles with two connections each can be supplied by means of one or more mixing distributors. The lubricant pipes should be run horizontally or slightly inclined.

Filtered oils with friction- and wear-reducing additives are recommended for the lubrication of the spindle bearings. More detailed specifications as well as the determination of cycle time and working pressure can be seen from the operating instructions.

Units

- **PRELUB GP 2 (Standard)**
2 Lubricating point connections
- **PRELUB GP 4**
4 Lubricating point connections
- **PRELUB GP 0**
For external mixing distributors (max. 4 lubricating point connections)

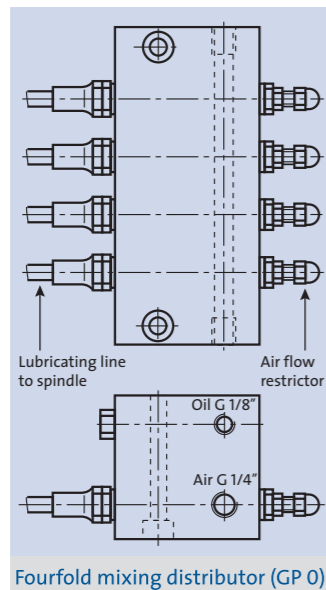

Benefits

Equipped with a whole array of features, the oil-air lubricator PRELUB GP offers the user considerable advantages:

- **Modular construction**
⇒ Control and mechanical part separate
- **Lubrication cycle interruption in the case of spindle standstill**
⇒ Saving of lubricant
- **Freely visible lubricant container that can be filled from outside made of limp plastic**
⇒ Direct optical filling level indication
- **Voltage range 90 ... 260 V AC**
⇒ Usable all over the world
- **Electronic control with display**
⇒ Fast setting of the parameters by simple menu guidance (plain text display)
- **Menu language selection (DE, ENG, ES, FR, IT, JP, CN)**
⇒ International understandable
- **Control can be connected to a PC**
⇒ Clear screen display of the menu structure
- **Enable signal, level signal**
⇒ Safe operation

Equipment

- **Air filter/regulator with manometer:**
Filter 5 µm
- **Interface with the machine tool control system to signal readiness for operation after checking:**
 - Oil level
 - Oil pressure and oil release pressure
 - Air pressure
 - Pre-lubricating cycle
- **Timer:**
Matching cycle time to oil viscosity and spindle data
- **Lubricating point connections:**
For PVC tubing, O.D. 6 mm
- **Operating voltage:**
90 ... 260 V AC, 50/60 Hz
- **Air supply G 1/4":**
 $p_{min} = 5 \text{ bar}$, $p_{max} = 10 \text{ bar}$
- **Power supply and monitoring via connector**
- **Dimensions:**
Appr. 489 x 432 x 222 mm (W x H x D);
Enclosure IP 55
- **Color:**
RAL 7032 (grey);
Other colors on request
- **Max. fuse protection:**
6 A



Accessory

Required accessories for the installation such as tubes, inspection manometer and filtered lubricating oil are available at GMN.

Diagram of pre-lubrication

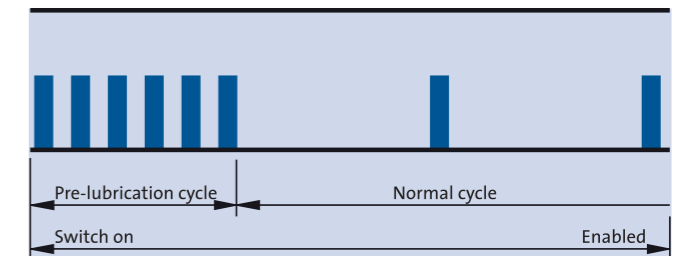

The time duration of the pre-lubrication is dependent on the length of the connected lubricating lines.

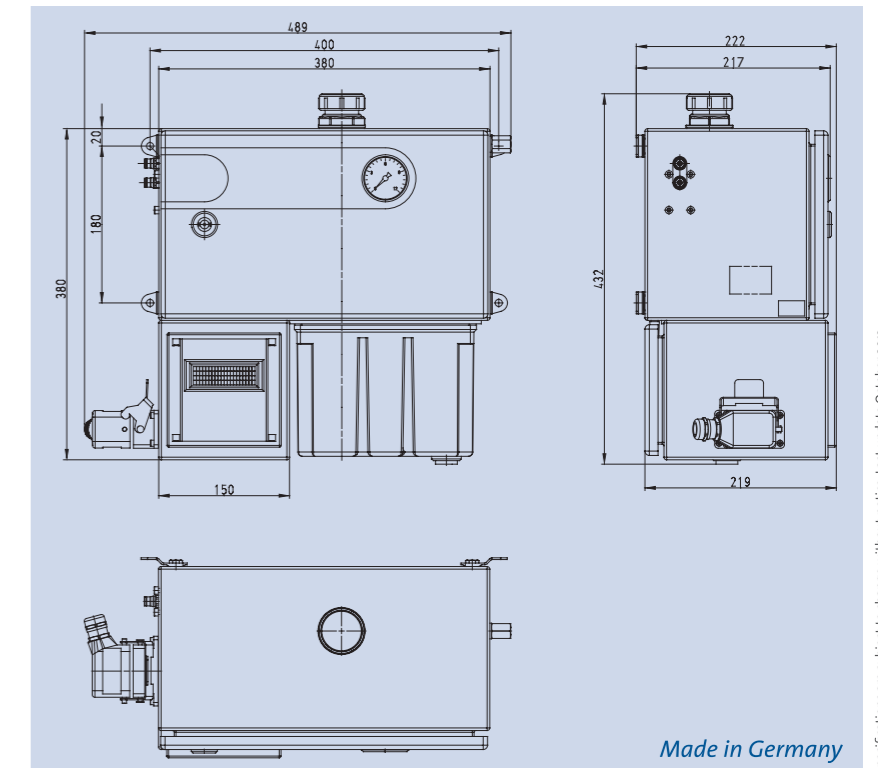

Made in Germany