



Sprag Type Freewheel Clutches

GMN Paul Müller Industrie GmbH & Co. KG

Aeussere Bayreuther Str. 230 · D-90411 Nuremberg

Phone: +49 (0) 911-5691-0 · Fax: +49 (0) 911-5691-221

www.gmn.de

Freewheels:

Phone: +49 (0) 911-56 91-418 · Fax: +49 (0) 911-5691-569

Mail: vertrieb.at@gmn.de

Official GMN representative:

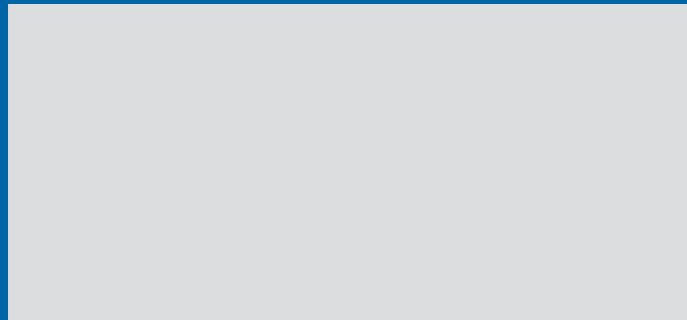

**Contents:****GMN**

Page 4–5

Sprag clutch technology

Page 6–7

Freewheel clutch selection

Page 9

GMN freewheel clutch types

Page 10–13

Clutch Components

Page 14–19

Sprags

Page 16

Cage

Page 17

Springs

Page 17

Mating rings

Page 18

Seals

Page 18

Ball bearings

Page 19

Roller bearings

Page 19

Torque Capacity

Page 20–23

Technical data

Page 24–55

GMN Complete
freewheel clutch units

Page 26–35

GMN Ball bearing
freewheel clutch units

Page 36–41

GMN Freewheel clutch
insert elements with rings

Page 42–45

GMN Freewheel clutch
insert elements

Page 46–53

GMN roller bearings
(accessory)

Page 54–55

Speed Limits

Page 57

Installation

Page 58

Tolerances

Page 59

Lubrication

Page 60–61

Service life

Page 62

Applications

Page 62–63

Selection Table

Page 64–65

Internet

Quality Management

Page 66



GMN Sprag type freewheel clutches

Based on its many years of experience in the development and production of high-quality machine components, GMN has chosen to specialize, within the field of freewheel-clutches, in the production of efficient, long-life sprag type freewheel clutches.

Emphasis is placed on the highest precision in the development and production of GMN sprag type freewheel clutches. This ensures their certification to international standards and produces consistent, outstanding quality characteristics with respect to torque handling, indexing reliability and long service life.

The standardized model series offer a large selection of feature options to furnish effective freewheel-clutch solutions for almost any field of application.

Sprag Type Freewheel Clutches

Function

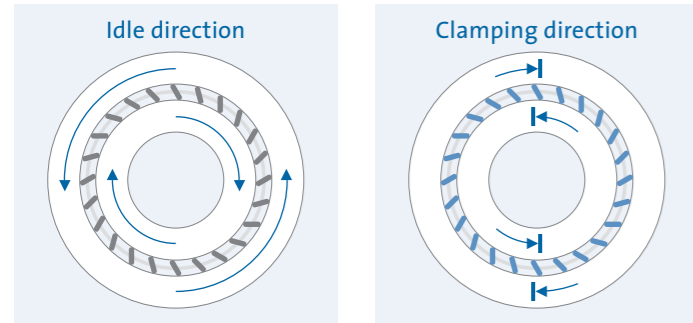

Freewheel clutches are machine elements which permit rotation in one direction (idle) and stop rotation or transmit torque in the opposite direction.

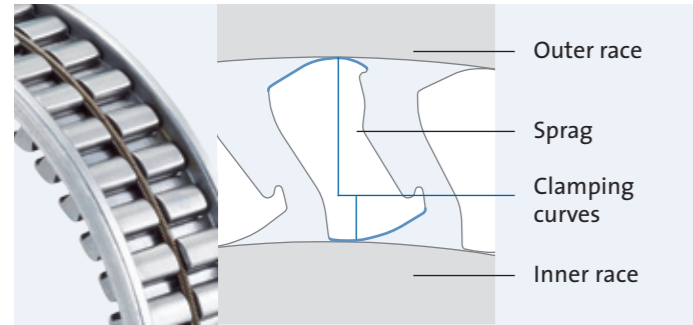

Driving/driven side

Force transfer takes place from the driving side to the driven side. Torque can be applied as desired, via the outer ring or the inner ring.

Idle direction

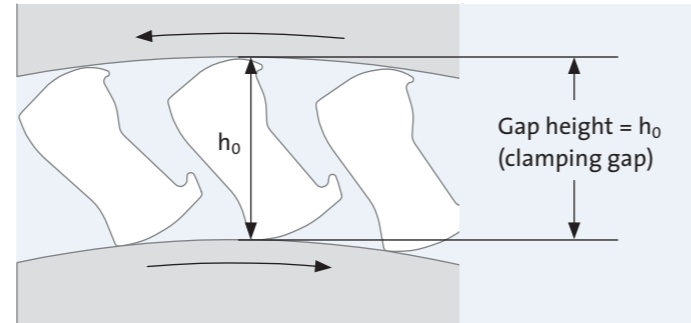

The sprags slide on the rotating raceway surfaces of the rings (sliding friction) in the idle direction. Torque is not transmitted from the driving side to the driven side under these conditions.

Gap height

The inner and outer rings define a constant gap height h_0 (start gap) in which the sprags slide over the raceways in the idle direction.

Spring system

The sprags are spring-loaded to ensure constant friction contact between the sprags and the rings.

Clamping direction

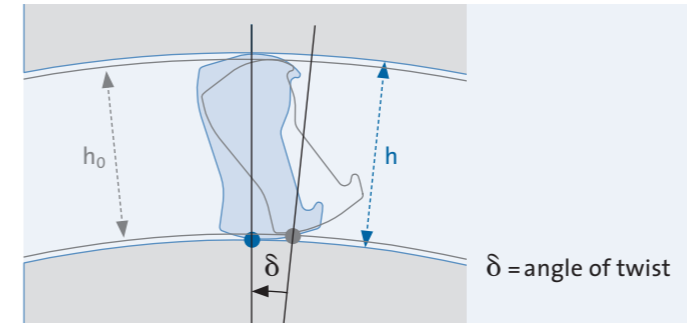

When rotating the clutch in the driving direction, the sprags will instantaneously engage to drive the races/rings in the desired direction. This instantaneous engagement is a result of static friction contact with the raceways because of the specifically designed clamping curve. Torque could be transmitted through the sprags now.

Angle of twist and torque transfer

As the force transfer increases, the sprags become more upright and expand the distance between the steel rings. This increased gap height is represented by h , and lies within the elastic deformation of the materials. The rings rotate with respect to each other in the amount of angle δ .

The rotation of the sprags ends when a balance of forces is established between the applied torque and the reaction forces exerted in the freewheel clutch. Subsequently the force is transmitted to the driven side.

The angle of twist δ is necessary to build up the balance of forces.

If the direction of rotation changes from the clamping direction to the idle direction, the system turns back in the opposite direction and the angle of twist reverses to the idle or start position. The rotation back and forth of the sprags from the driving to idle positions occur with a high degree of repeatability and precision.

Applications



Backstop

A Backstop application is where rotation is allowed in one direction and stopped in the opposite.



Indexing clutch

A repeated drive then idle motion will be transferred to the driven side, step by step, as rotary motion in one direction (the clamping direction).



Overrunning clutch

If the speed of the driven side exceeds the speed of the driving side, the freewheel-clutch disengages the driving and driven sides by switching from torque transmit to idle.

All GMN Freewheel clutches can be used for backstop, indexing or for overrunning clutch applications.

GMN Sprag Type Freewheel Clutches

GMN Sprag Type Freewheel Clutches Products

Complete freewheel clutch units



- + Freewheel clutch insert element
- + Inner and outer ring
- + Ball bearing
- + Roller bearing
- + Seals (optional)

Ball bearing freewheel clutch units



- + Freewheel clutch insert element
- + Inner and outer ring
- + Ball bearing
- + Seals (optional)

Freewheel clutch insert elements with rings



- + Freewheel clutch insert element
- + Inner and outer ring

Freewheel clutch insert elements



- + Freewheel clutch insert element

Freewheel selection

GMN offers highly effective, long-life freewheel solutions for many applications.

All GMN Freewheel clutches can be used as backstop, indexing or for overrunning clutch applications.

The proper selection of the optimal Freewheel clutch for any application must include many design aspects:

1. Type (features of surrounding construction)
2. Size and torque requirements
3. Mode of operation (suitable spring system)

1. Type

Selection of a suitable GMN Clutch can be influenced by existing shaft and housing design characteristics:

The shaft and housing are already hardened to specification:

Freewheel-clutch insert elements: GMN series FE

If hardened mating rings are required:

Freewheel-clutch insert elements with inner and outer ring: GMN series FR, FRN

If bearing support is required:

Ball bearing- / complete freewheel clutch units:

GMN series FK, FKN, FKNN, FP, FN

If integrated lubrication and sealing is required :

Pre-lubricated ball bearing- / complete freewheel clutch units

GMN series FPD, FND, RA, FK 2RS, FKN 2RS, FKNN 2RS

2. Size and torque

All GMN clutches are available in many different sizes and performance classes (*Size tables: Pg. 24–55*).

3. Mode of operation (design / spring system)

Selection of a suitable spring system requires particular consideration with respect to the intended mode of operation:

Indexing clutch:

Spring system: meander spring (M)

Backstop:

Spring system: tension spring (Z)

Overrunning clutch:

Spring system: tension spring (Z) or meander spring (M)

Custom solutions

The production of a custom GMN Clutch solution is possible on request.

GMN Sprag Type Freewheel Clutches

GMN Complete freewheel clutch units

Powerful and compact complete clutch solutions with integrated fixed and floating bearings for high torque requirements.

Series: FPD



Components:

Insert element
FE 400 Z / FE 400 M

- + Raceway rings
 - Inner ring press fit
 - Outer ring press fit
- + Ball bearing
- + Roller bearing
- + Oil lubrication
- + GMN rubber seals

Width:
34 mm

Operating temperature:
max. 100°C

(Pg. 26–27)

Series: FND



Components:

Insert element
FE 400 Z / FE 400 M

- + Raceway rings
 - Inner ring keyway
 - Outer ring press fit
- + Ball bearing
- + Roller bearing
- + Oil lubrication
- + GMN rubber seals

Width:
34 mm

Operating temperature:
max. 100°C

(Pg. 28–29)

Series: RA



Components:

Insert element
FE 400 Z

- + Raceway rings
 - Inner ring keyway
 - Outer ring mounting tab
- + Ball bearing
- + Roller bearing
- + Oil lubrication
- + GMN rubber seals

Width:
34 mm

Operating temperature:
max. 100°C

(Pg. 30–31)

Series: FP



Components:

Insert element
FE 400 Z / FE 400 M

- + Raceway rings
 - Inner ring press fit
 - Outer ring press fit
- + Ball bearing
- + Roller bearing

Lubrication:
Oil or grease

Width:
27 mm

Operating temperature:
max. 140°C
Higher temp. on request

(Pg. 32–33)

Series: FN



Components:

Insert element
FE 400 Z / FE 400 M

- + Raceway rings
 - Inner ring keyway
 - Outer ring press fit
- + Ball bearing
- + Roller bearing

Lubrication:
Oil or grease

Width:
27 mm

Operating temperature:
max. 140°C
Higher temp. on request

(Pg. 34–35)

GMN Ball bearing freewheel clutch units

Economical freewheel-clutch solutions with integrated ball bearings for small to medium torque requirements in standardized dimensions of ball bearing series 62 (DIN 625).

Series: FK (2RS)

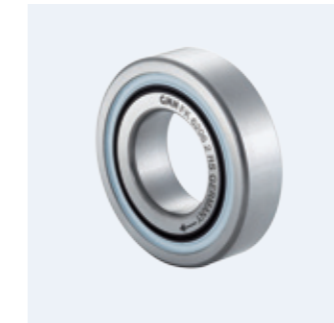

Components:

Insert element
FE 400 Z2

- + Raceway rings
 - Inner ring press fit
 - Outer ring press fit
- + Ball bearing
- + Grease lubrication*
- + RS seals*

Width:
12 / 14 / 15 / 16 / 17 / 18 mm

Operating temperature:
max. 140°C
max. 170 °C on request
max. 110°C (series 2RS)

(Pg. 36–37)

Series: FKN (2RS)



Components:

Insert element
FE 400 Z2

- + Raceway rings
 - Inner ring keyway
 - Outer ring press fit
- + Ball bearing
- + Grease lubrication*
- + RS seals*

Width:
12 / 14 / 15 / 16 / 17 / 18 mm

Operating temperature:
max. 140°C
max. 170 °C on request
max. 110°C (series 2RS)

(Pg. 38–39)

Series: FKNN (2RS)

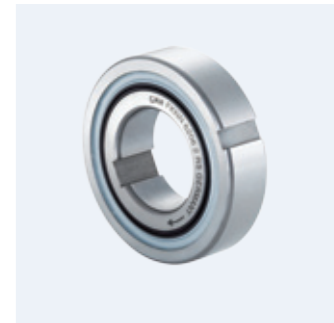

Components:

Insert element
FE 400 Z2

- + Raceway rings
 - Inner ring keyway
 - Outer ring keyway
- + Ball bearing
- + Grease lubrication*
- + RS seals*

Width:
12 / 14 / 15 / 16 / 18 mm

Operating temperature:
max. 140°C
max. 170 °C on request
max. 110°C (series 2RS)

(Pg. 40–41)

*Ball bearing freewheel clutches are offered with no seals or two seals (2RS). The seals do not effect the width requirement of the clutches. The double-sealed type is greased for lifetime. GMN ball bearing freewheels without seals are suitable for either oil or also grease lubrication.

GMN Sprag Type Freewheel Clutches



GMN Freewheel clutch insert elements with rings

Series FR and FRN consist of a freewheel clutch insert element and hardened and ground thrust rings.

Series: FR



Components:

Insert element
FE 400 Z / FE 400 M

- + Raceway rings
 - Inner ring press fit
 - Outer ring press fit

Lubrication:
Oil or grease

Width:
12 mm

Operating temperature:
max. 140°C
Higher temp. on request
(Pg. 42–43)

Series: FRN



Components:

Insert element
FE 400 Z / FE 400 M

- + Raceway rings
 - Inner ring keyway
 - Outer ring press fit

Lubrication:
Oil or grease

Width:
12 mm

Operating temperature:
max. 140°C
Higher temp. on request
(Pg. 44–45)

GMN Freewheel clutch insert elements

A freewheel clutch insert element consists of a cage, a spring and a size dependent number of sprags.



All GMN Freewheel clutch units and ball bearing free-wheel clutch units are equipped with an insert element of series FE 400 M, FE 400 Z or FE 400 Z2.

Complete freewheel clutch units:

Series FPD, FND, RA, FP, FN

Freewheel clutch insert element:

FE 400 Z, FE 400 M

Ball bearing freewheel clutch units:

Series FK, FKN, FKNN

Freewheel-clutch insert element:

FE 400 Z2

Freewheel clutch insert elements with rings:

Series FR, FRN

Freewheel clutch insert elements:

FE 400 Z, FE 400 M

Note

Freewheel clutch insert elements are not self-centering. They require external bearing support to ensure concentricity of the shaft to the housing.

Series: FE 400 Z



Components:

- Sprags
- Spring: tension spring
- Cage: steel / plastic

Lubrication:
Oil or grease

Width/installed width:
11 mm / 12 mm

Operating temperature:
max. 170°C (steel cage)
max. 140°C (plastic cage)

(Pg. 46–47)

Series: FE 400 M



Components:

- Sprags
- Spring: meander spring
- Cage: steel

Lubrication:
Oil or grease

Width/installed width:
11 mm / 12 mm

Operating temperature:
max. 170°C

(Pg. 48–49)

Series: FE 400 Z2



Components:

- Sprags
- Spring: tension spring
- Cage: steel / plastic

Lubrication:
Oil or grease

Width/installed width:
6.3 mm / 7 mm

Operating temperature:
max. 170°C (steel cage)
max. 140°C (plastic cage)

(Pg. 50–51)

Series: FE 8000 Z



Components:

- Sprags
- Spring: tension spring
- Cage: steel

Lubrication:
Oil or grease

Width/installed width:
16 mm / 16.5–18 mm
19 mm / 19.5–21 mm
25 mm / 25.5–27 mm

Operating temperature:
max. 170°C

(Pg. 52–53)

GMN Freewheel Clutch Components

GMN Sprag Type Freewheel Clutches Freewheel Clutch Components

Components

Use of the highest quality components is the basis for the outstanding performance and the long service life exhibited by GMN sprag type freewheel clutches.

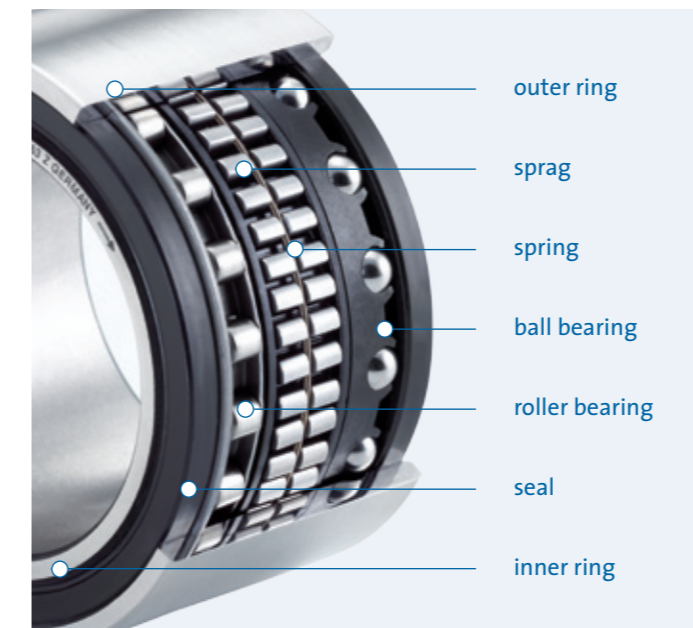

Freewheel clutch insert elements

GMN series FE 400 Z, FE 400 M, FE 400 Z2 and FE 8000 have, as their basic components, sprags, sprag cage and spring. GMN series FR and FRN additionally include inner and outer rings which are intended for press-fit or key way connect to the mating parts.

Ball bearing freewheel clutch units

GMN series FK, FKN and FKNN are additionally equipped with ball bearings.

RS series with RS seals

Complete freewheel clutch units

GMN series FP and FN are distinguished by an integrated ball bearing and an additional roller bearing.

Series FPD, FND and RA with GMN rubber seals

Performance features

GMN Sprag type freewheel clutches are distinguished by compact construction and exhibit outstanding performance characteristics with respect to torque, indexing accuracy, indexing frequency and service life.

Minimal sprag size

- Space very small

Low sprag mass

- Minimal inertia
- High indexing frequencies

High density of installed sprags

- Maximum torque capacity in minimal space

Highly precise clamping curve geometry (logarithmic spirals)

with a constant clamping angle

- Minimum indexing delay due to small angle of twist
- Homogeneous load distribution independent individual sprag angle.
- No localized material stress peaks.

Exact spring force

- Highly reliable indexing with repetition accuracy

GMN Freewheel Clutch Components

Sprags

The compact size of these sprags in combination with their highly precise production geometry result in outstanding performance characteristics.

Clamping angle and clamping curve: The specific shape of the clamping curve along the sprags' inner and outer race defines in contact with the round mating parts (shaft and housing) the clamping angle α .

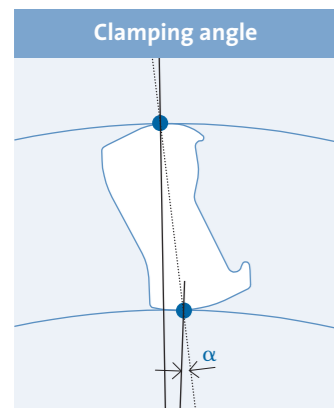

The correct function of the sprag relies on a specific clamping angle.

$$\mu > \tan \alpha$$

μ = static friction coefficient
 α = clamping angle

As long as the tangent of the clamping angle is smaller than the coefficient of static friction μ , the sprags will be in static friction contact with the connecting parts when load is applied.

Material:

Bearing steel 100Cr6 (material number: 1.3505)
Hardness: HRC = 60⁺⁴ (HV = 700⁺¹⁰⁰)

Mating parts:

The geometry of the clamping curve is designed for steel mating parts – raceways in other materials are not permissible.

Sprag series 400

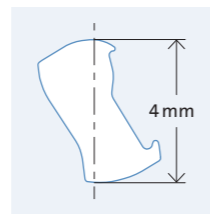

The small sprag size permits high sprag density and thus maximum performance in a minimum of space. The low inertia of sprags also makes it possible to achieve extremely high indexing frequencies of up to 60 Hz.

Height (radial) in idle position: 4 mm
Widths: 5 / 8 mm (for tension spring)
8 mm (for meander spring)

Clamping curve geometry: Logarithmic spiral

Clamping angle: Constant

Sprag characteristic: Lift off inner ring at high speed



Sprag series 8000

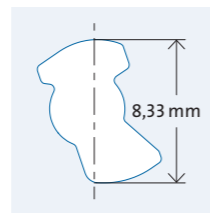

To achieve maximum torque capacity with the larger 8000 series sprag the profile was adjusted with a slightly higher clamping angle. Due to the center of gravity's position the design is not lifting off and provides indexing reliability even in high speed applications.

Height (radial) in idle position: 8.33 mm
Widths: 13 / 16 / 22 mm (for tension spring)

Clamping curve geometry: Compound circles

Clamping angle: Increasing

Sprag characteristic: Press towards inner ring at high speed



Sprag cage

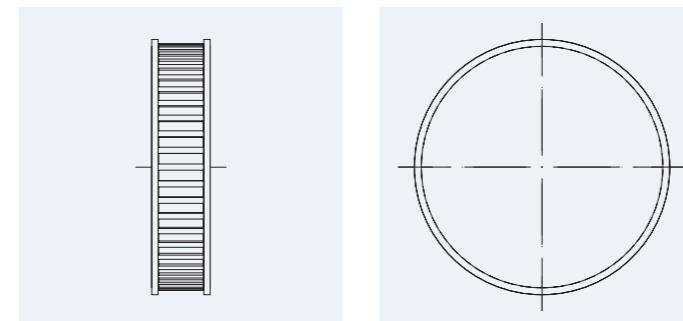

The sprags are evenly spaced around the circumference of the insert element cage. The insert element cage does not come in contact with the inner or outer races; it remains absolutely load free under any application.

GMN Sprag type freewheel clutches with a plastic cage in their standard design are also available as a special design with a steel cage on request.

Operating temperature:
Steel cage: max. 170°C
Plastic cage: max. 140°C

Spring

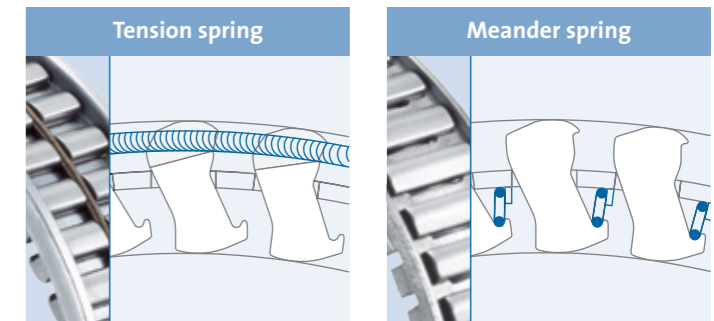

GMN offers two different spring systems which maintain a constant friction contact between sprags and the mating parts.

Tension spring

The GMN tension spring is a circular spring that envelops all of the sprags and provides them with a collective spring force. The spring force per sprag is slightly less than that of a meander spring. This results in a longer service life in idle. The max. indexing frequency is $f_{max} = 10$ Hz.

Series with tension springs:

- Freewheel clutch insert element: FE 400 Z, FE 400 Z2, FE 8000 Z
- Freewheel clutch insert elements with rings: all series
- Ball bearing freewheel clutches: all series
- Complete freewheel clutch units: all series

Meander spring

A 3-dimensionally bent spring that loads each sprag separately (individual spring force for each sprag). The structural characteristics of this spring increases transferable torque by about 10% (in comparison to tension springs) because maximum sprag line contact to race is achieved. The max. indexing frequency is $f_{max} = 60$ Hz.

Series with meander springs:

- Freewheel clutch insert element: FE 400 M
- Freewheel clutch insert elements with rings: all series
- Complete freewheel clutch units: all series

Mode of operation	Spring system
Indexing clutch	Meander spring
Backstop	Z spring
Overrunning clutch	Meander or Z spring

GMN Freewheel Clutch Components

Rings



GMN Freewheel clutch rings are made of hardened and ground ball bearing steel.

Press fit installation

The thin wall thickness (2–2.5 mm) of the rings for press fit permits installation within a limited space requirement. The rings are designed to achieve the optimal start gap height (h_0) only after the rings are pressed into the housing and onto the shaft (see tolerance tables). Press fit installation guarantees transmission of maximum torque capacity.

Keyway installation

All GMN rings with a keyway are designed for light press fit to support torque transfer. A key connection alone without a press fit will be insufficient to achieve maximum torque transfer.

Series with rings:

- Freewheel clutches with rings: all series
- Ball bearing freewheel clutches: all series
- Complete freewheel clutch units: all series

Properties:

- 100Cr6 (material number 1.3505)
- Hardness: HRC 60⁺⁴ (HV 700⁺¹⁰⁰)
- Surface: Rz ≤ 2.5 μm (Ra ≤ 0.4)

Seals



GMN rubber seals

GMN Complete freewheel clutch units in series FPD, FND and RA are equipped with effective round seals that protect the freewheel clutch from external contamination and keep the oil filling reliably inside.

Series with GMN round seals

Complete freewheel clutch units: Series FPD, FND and RA

Operating temperature:

max. 100°C

RS seals

GMN ball bearing freewheel clutches that integrate RS seals protect the clutch from external contamination and keep the lubrication inside the clutch.

Series with RS seals

Ball bearing freewheel clutch units: 2RS designs

Operating temperature:

max. 110°C

Ball bearings



GMN Ball bearing freewheel clutch units and complete freewheel clutch units have standard ball bearings integrated.

The rings each have a ground-in ball bearing raceway and form a unit with the balls, which cannot be disassembled.

The ball bearing raceways for all inner and outer rings are individually measured and paired.

Bearing clearance between C3 and C5 is established according to the tolerance fields of the mating parts after press-fitting the freewheel clutch.

Minimum bearing clearance C3 is achieved with the largest dimension of the shaft's diameter and the smallest dimension of the bore diameter (housing).

Ball bearing freewheel clutch units:

- Ball bearing freewheel clutch units: all series
- Complete freewheel clutch units: all series

Balls:

- Diameter: 5 mm
- Material: 100Cr6 (material number: 1.3505)

Ball cage:

- Plastic (PA)
- (ball bearing freewheel clutch units sizes 6204 and 6205: brass)

Roller bearings



GMN series RL 400 roller bearings are available as an option for GMN freewheel clutch insert elements: FE 400, FE 400 Z and FE 400 Z2.

GMN Roller bearings with the tolerance "-4" (4 μm smaller than nominal dimension) are produced both as components for GMN Complete freewheel clutch units and as separate accessories.

For applications with reduced bearing clearance tolerance "0" is also available on request. (order designation: RL 432-0)

Series with roller bearings:

Complete freewheel clutch units: all series

Materials:

- Rollers: 100Cr6 (material number: 1.3505)
- Roller cage: steel (RL 448 and RL 443: brass)

Operating temperature (max.):

- 170°C
- (RL 448 and RL 443: 150°C)



Torque

GMN Sprag Type Freewheel Clutches Torque

Torque development

As the force transfer increases in driving direction, the sprags become more upright and expand the clamping gap between the rings elastically.

When nominal gap height h_{nom} is reached, the freewheel clutch will transmit its nominal torque T_{nom} ; at the maximum gap height h_{max} its maximum torque T_{max} .

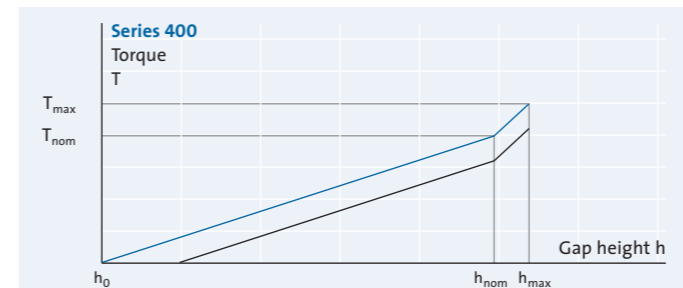

- Torque development for optimal start gap h_0 .
- Torque development for start gap $h > h_0$. The gradient of the graph remains unchanged, nominal and maximum torque are reduced.

Insert element	Start gap height h_0	Nom. gap height h_{nom}	Max. gap height h_{max}
Series 400	4.00 mm	4.06 mm	4.07 mm
Series 8000	8.33 mm	8.46 mm	8.6 mm

The maximum gap height (h_{max}) is a consequence of the sprag geometry.

Torque limit

- A load-dependent stress reaction is built up in the sprags and the mating parts.
- The linear contact of the sprags along the clamping curves with the mating parts is evaluated according to the Hertzian model.
- The sprags expand the gap. Maximum gap height is determined by the geometry of sprags.

The freewheel clutch's nominal and maximum torque are defined by reaching one of the relevant limits.

Torque	Gap height	Hertzian pressure	perm. tension
M_{nom}	Nom. gap height	4,200 MPa	$\sigma_{perm. ab}$ all participating components
M_{max}	Max. gap height	4,600 MPa	

Stresses

Sprags as well as the rings are loaded in the contact area by tangential and radial stress.

Bending stresses $\sigma_{BS perm.}$ is valid as an equivalent stress for this load.

Material	$\sigma_{BS perm.}$	Hardness
34 CrMo 4V	400 MPa	case hardened HRC = 60 ⁺⁴ ; Eht = 1.3 mm
16 MnCr 5	400 MPa	case hardened HRC = 60 ⁺⁴ ; Eht = 1.3 mm
20 MnCr 5	600 MPa	case hardened HRC = 60 ⁺⁴ ; Eht = 1.3 mm
100 Cr 6	750 MPa	hardened and tempered HRC = 60 ⁺⁴

Yield strength R_e is the applicable load limit for all other components in press fits.

Freewheel clutches in a row

Rough calculation of the torque capacity for a maximum of 3 freewheel clutches in a row:

- 2 freewheel clutches in a row: 90% of the sum of individual torque capacity
- 3 freewheel clutches in a row: 80% of the sum of individual torque capacity

Torque

Nominal torque

The nominal torque (T_{nom}) (size tables Pg. 24–55) describes the torque that the freewheel clutch can transfer as a continuous load.

The calculation of nominal torque is based on a standardized surrounding construction.

- Solid shaft
- Mating parts material: 100Cr6 hardened and tempered; HRC = 60+4
- Wall thickness ratio $D/DL = 1.4$
- Calculative width W_c

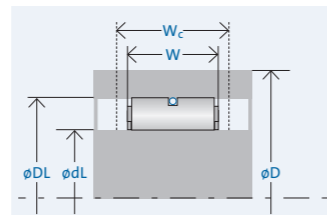

- W = width
- W_c = calculative width
- FE 400: $W_c = 15$ mm
- FR/FRN: $W_c = 15$ mm
- FP/FN/FPD/FND/FK/FKN: $W_c = W$
- FE 8000: $W_c = W + 3$ mm

Deviating characteristics in the surrounding construction have an influence on nominal torque.

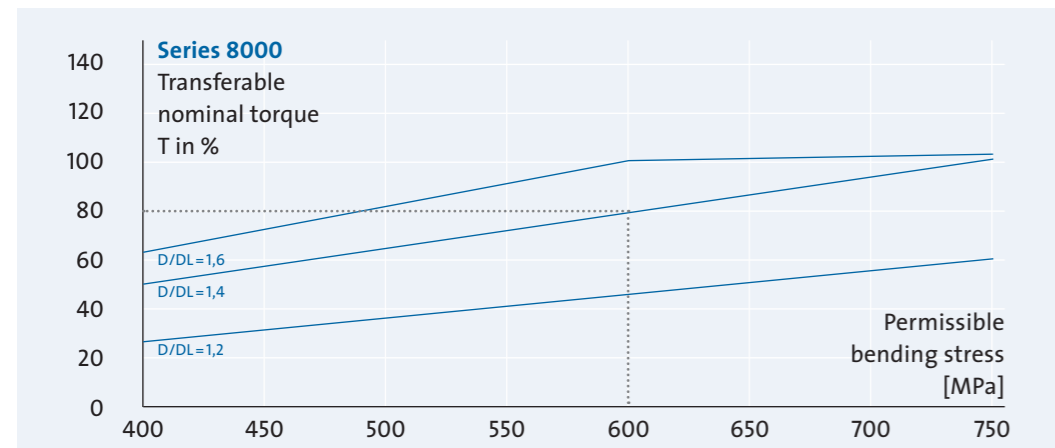
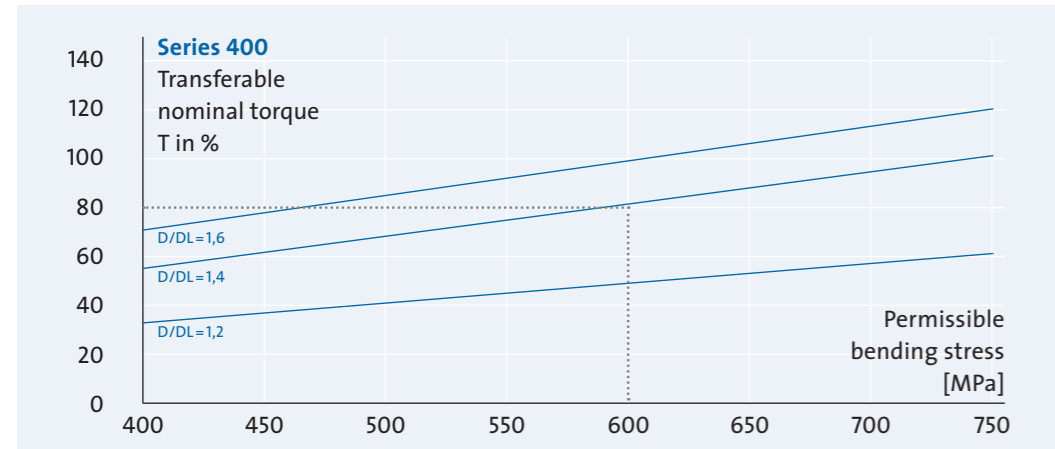

Example for 20 MnCr5 - $D/DL = 1.4$

Influence of the mating parts stiffness on the nominal torque.
(wall thickness ratios: $D/DL = 1.2 / 1.4 / 1.6$)

Maximum torque

If the load exceeds the specified nominal torque (T_{nom}) the clamping angle changes and rises steeply to increase gap height to its maximum permissible dimension (h_{max}).

Depending on type and surrounding construction, the maximum torque (T_{max}) is 1.5 to 2 times the specified nominal torque. Please note that maximum torque capacity cannot be transferred in continuous operation.

Overload protection

If the applied torque exceeds the maximum permissible value (T_{max}), static friction contact is loosened between the sprags and the rings and the clutch slips.

Drag torque

In idle direction the freewheel clutch shows only a very low drag torque to overcome the sliding friction between sprags and the rings. Drag torque is increased in sealed freewheel clutches: ball bearing freewheel clutch units, $T_s = 0.01$ to 0.05 Nm. complete freewheel clutch units, $T_s = 0.1$ to 0.3 Nm

Torque calculation

The GMN calculation program determines specific nominal torque with consideration for all influencing factors.

The analysis of a given surrounding construction can reveal optimization potential for mating parts, provide performance enhancing design advisories and offer support in the selection of a suitable freewheel-clutch.





GMN
Sprag Type Freewheel Clutches
Technical Data

Complete freewheel clutch units

FPD (Pg. 26-27)



FND (Pg. 28-29)



RA (Pg. 30-31)



FP (Pg. 32-33)



FN (Pg. 34-35)



Ball bearing freewheel clutch units

FK (Pg. 36-37)



FKN (Pg. 38-39)



FKNN (Pg. 40-41)



Freewheel clutch insert elements with rings

FR (Pg. 42-43)



FRN (Pg. 44-45)



Freewheel clutch insert elements

FE 400 Z (Pg. 46-47)



FE 400 M (Pg. 48-49)



FE 400 Z2 (Pg. 50-51)

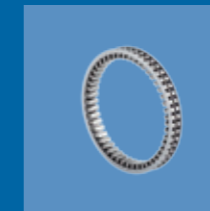

FE 8000 Z (Pg. 52-53)



Complete Freewheel Clutch Unit FPD

with seals

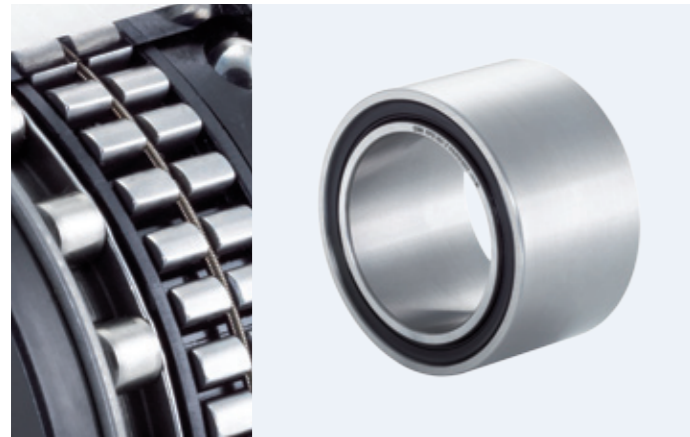

Characteristics

Width
34 mm

Operating temperature
max. 100° C

Lubrication

Operative lifetime oil lubrication

Installation

Installation tolerances
Shaft h5; hub H6

Mating parts

Hardening and grinding of the mating parts is not necessary. Thoroughly clean (grease free) the mating parts in the vicinity of the freewheel clutch as well as the freewheel clutch's rings before making the press fit.

Bearing

The freewheel clutch includes ball and roller bearings. Additional external bearing support is not necessary.

Press fit pressure

Press fit pressure must not be applied to the balls.

Clamping direction

The arrow on the inner ring designates the inner ring's clamping direction.

Components

Freewheel clutch insert element* FE 400 M (meander spring)
FE 400 Z (tension spring)

+ Raceways Bearing steel, hardened and ground
inner ring Press fit
outer ring Press fit

+ Ball bearing Integrated

+ Roller bearing RL 400

+ Lubrication Lifetime oil lubrication

+ Seal GMN rubber seal

* available with either freewheel clutch insert element FE 400 M (meander spring) or FE 400 Z (tension spring).

Data

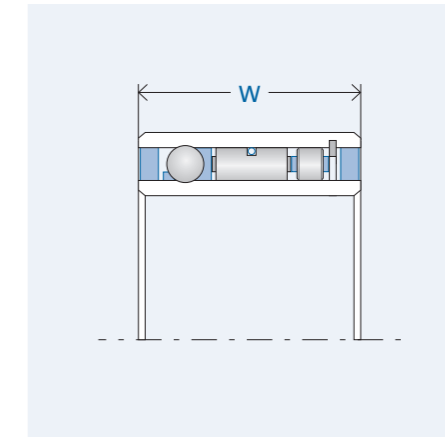
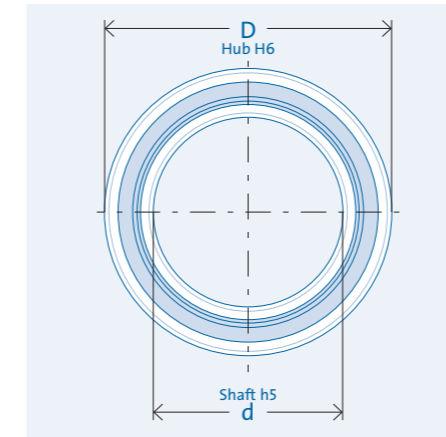

Drawing legend

- d = inner diameter
- D = outer diameter
- W = width
- T = torque
- n = rotation speed
- C = load capacity

Designation	d [mm]	D [mm]	W [mm]	T _{nom} [Nm]	n _{max} [rpm]	C _{dyn.} [N]	C _{stat.} [N]	Weight [kg]	Item no.
FPD 427 M	15	31	34	94	2,000	7,679	6,397	0.09	306516
FPD 427 Z	15	31	34	84	2,000	7,679	6,397	0.09	306517
FPD 432 M	20	36	34	133	1,800	8,104	7,241	0.12	306518
FPD 432 Z	20	36	34	121	1,800	8,104	7,241	0.12	306519
FPD 437 M	25	41	34	176	1,700	9,201	8,142	0.15	306520
FPD 437 Z	25	41	34	160	1,700	9,201	8,142	0.15	306521
FPD 442 M	30	46	34	223	1,500	10,247	10,708	0.18	300696
FPD 442 Z	30	46	34	208	1,500	10,247	10,708	0.18	300697
FPD 448 M	35	53	34	286	1,300	11,642	13,440	0.23	306524
FPD 448 Z	35	53	34	262	1,300	11,642	13,440	0.23	306525
FPD 453 M	40	58	34	343	1,200	11,417	13,577	0.26	300702
FPD 453 Z	40	58	34	314	1,200	11,417	13,577	0.26	300700
FPD 463 M	50	68	34	461	1,100	13,070	17,063	0.34	306534
FPD 463 Z	50	68	34	428	1,100	13,070	17,063	0.34	306535
FPD 473 M	60	78	34	588	1,000	14,128	19,896	0.41	306536
FPD 473 Z	60	78	34	543	1,000	14,128	19,896	0.41	306537

The specified nominal torque is based on sufficient stiffness of mating parts (Pg. 22)
Rotation speed n = speed difference of mating parts

Complete Freewheel Clutch Unit FND

with seals and keyway (IR)

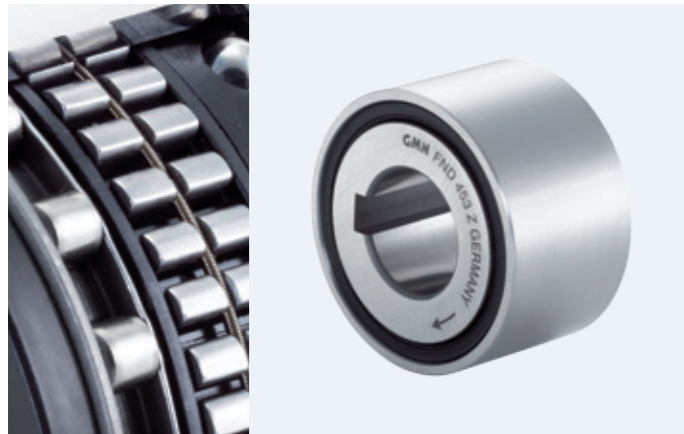

Components	
Freewheel clutch insert element*	FE 400 M (meander spring) FE 400 Z (tension spring)
+ Raceways	Bearing steel, hardened and ground
inner ring	Keyway per DIN 6885, Sheet 1 Tolerance: P9 with back clearance
outer ring	Press fit
+ Ball bearing	Integrated
+ Roller bearing	RL 400
+ Lubrication	Lifetime oil lubrication
+ Seal	GMN rubber seal

* available with either freewheel clutch insert element FE 400 M (meander spring) or FE 400 Z (tension spring).

Characteristics

Width
34 mm

Operating temperature
max. 100°C

Lubrication

Operative lifetime oil lubrication

Installation

Installation tolerances
Shaft js6 (k5); hub H6

Mating parts

Hardening and grinding of the mating parts is not necessary. Thoroughly clean (grease free) the mating parts in the vicinity of the freewheel clutch as well as the freewheel clutch's rings before making the press fit.

Bearing

The freewheel clutch includes ball and roller bearings. Additional external bearing support is not necessary.

Press fit pressure

Press fit pressure must not be applied to the balls.

Clamping direction

The arrow on the inner ring designates the inner ring's clamping direction.

Data

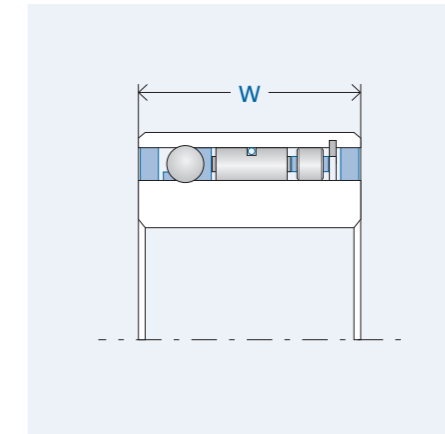
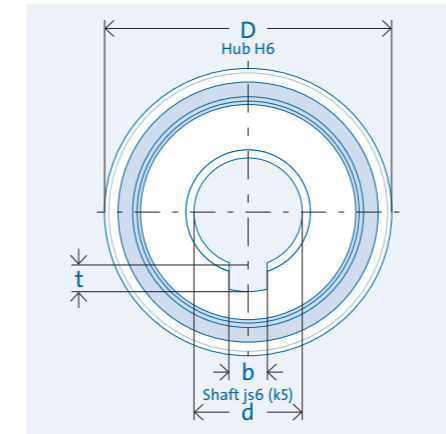

Drawing legend

- d = inner diameter
- D = outer diameter
- W = width
- T = torque
- n = rotation speed
- C = load capacity
- b = keyway width
- t = keyway depth

Designation	d [mm]	D [mm]	W [mm]	T _{nom} [Nm]	n _{max} [rpm]	C _{dyn.} [N]	C _{stat.} [N]	Weight [kg]	b [mm]	t [mm]	Item no.
FND 437 M	15	41	34	176	1,700	8,962	8,661	0.24	5	2.3	300737
FND 437 Z	15	41	34	161	1,700	8,962	8,661	0.24	5	2.3	300738
FND 442 M	20	46	34	223	1,500	10,247	10,708	0.28	6	2.8	300743
FND 442 Z	20	46	34	208	1,500	10,247	10,708	0.28	6	2.8	300744
FND 453 M	25	58	34	343	1,200	11,417	13,577	0.46	8	3.3	300751
FND 453 Z	25	58	34	314	1,200	11,417	13,577	0.46	8	3.3	300752
FND 459 M	30	64	34	411	1,100	12,691	16,320	0.55	8	3.3	300758
FND 459 Z	30	64	34	381	1,100	12,691	16,320	0.55	8	3.3	300760
FND 463 M	35	68	34	462	1,100	13,070	17,063	0.60	10	3.3	306528
FND 463 Z	35	68	34	428	1,100	13,070	17,063	0.60	10	3.3	306529
FND 470 M	40	75	34	550	1,000	14,050	19,840	0.69	12	3.3	300765
FND 470 Z	40	75	34	509	1,000	14,050	19,840	0.69	12	3.3	300766
FND 473 M	45	78	34	588	1,000	14,128	19,896	0.73	14	3.8	306532
FND 473 Z	45	78	34	543	1,000	14,128	19,896	0.73	14	3.8	306533

The specified nominal torque is based on sufficient stiffness of mating parts (Pg. 22) and refers to the integrated insert element, not the key way. Rotation speed n = speed difference of mating parts

Complete Freewheel Clutch Unit RA

with seals, keyway (IR) and mounting tab (OR)

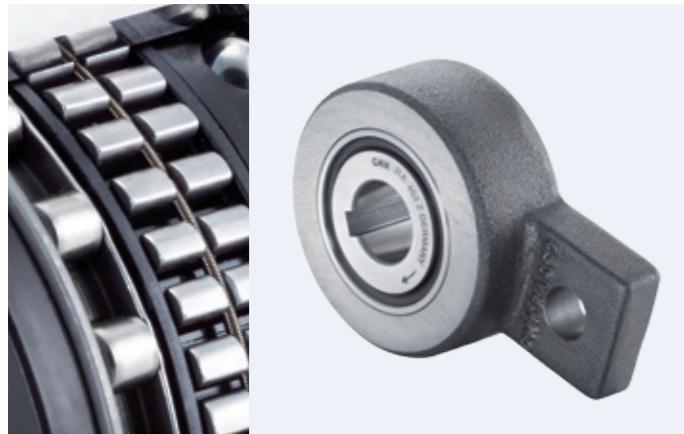

Components

Freewheel clutch insert element Complete freewheel clutch unit, series FND FE 400 Z (tension spring)

+ Raceways inner ring Bearing steel, hardened and ground
Keyway per DIN 6885, Sheet 1 P9 with back clearance

outer ring With mounting tab (cast steel or steel)*

+ Ball bearing Integrated

+ Roller bearing RL 400

+ Lubrication Lifetime oil lubrication

+ Seal GMN rubber seal

* Not suitable for indexing freewheel clutch applications.

Characteristics

Width
34 mm

Operating temperature
max. 100°C

Lubrication

Operative lifetime oil lubrication

Installation

Installation tolerances
Shaft js6 (k5)

Mating parts

Hardening and grinding of the mating parts is not necessary. Thoroughly clean (grease free) the mating parts in the vicinity of the freewheel clutch as well as the freewheel clutch's rings before making the press fit.

Bearing

The freewheel clutch includes ball and roller bearings. Additional external bearing support is not necessary.

Press fit pressure

Press fit pressure must not be applied to the balls. Installation/removal through inner ring only.

Clamping direction

The arrow on the inner ring designates the inner ring's clamping direction.

Mounting tab

Mounting tab must not be fixed to the housing tight.

Data

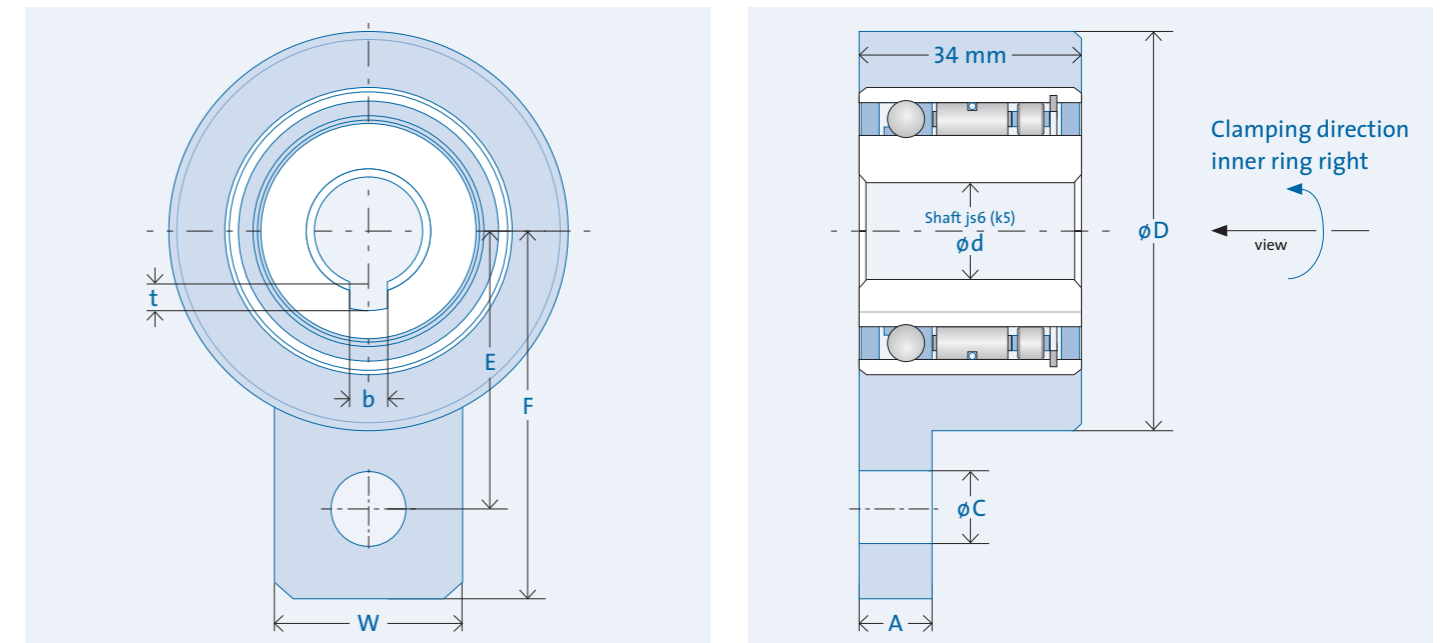

Designation	d [mm]	D [mm]	A [mm]	W [mm]	C [mm]	E [mm]	F [mm]	T _{nom} [Nm]	n _{max} [rpm]	C _{dyn.} [N]	C _{stat.} [N]	Weight [kg]	b [mm]	t [mm]	Item no.
RA 437 Z	15	65	12	32	10	47	62	161	1,700	8,962	8,661	0.81	5	2.3	301026
RA 442 Z	20	75	16	36	12	54	72	208	1,500	10,247	10,708	1.08	6	2.8	301030
RA 453 Z	25	90	16	45	16	62	84	314	1,200	11,417	13,577	1.50	8	3.3	301043
RA 459 Z	30	100	16	50	16	68	92	381	1,100	12,691	16,320	1.81	8	3.3	301048
RA 463 Z	35	100	16	50	16	68	92	428	1,100	13,070	17,063	1.75	10	3.3	306681
RA 470 Z	40	110	20	50	20	85	115	509	1,000	14,050	19,840	2.28	12	3.3	301056
RA 473 Z	45	110	20	50	20	85	115	543	1,000	14,128	19,896	2.2	14	3.8	306682

Inner ring clamping direction left available on request. Rotation speed n = shaft speed
The specified nominal torque refers to the integrated freewheel clutch insert element, not the key way.

Drawing legend

- E = bore spacing
- F = support lever length
- T = torque
- n = rotation speed
- C = mounting tab bore
- d = inner diameter
- b = keyway width
- t = keyway depth
- D = outer diameter
- B = mounting tab width
- A = mounting tab thickness

Complete Freewheel Clutch Unit FP

for press fit (IR and OR)

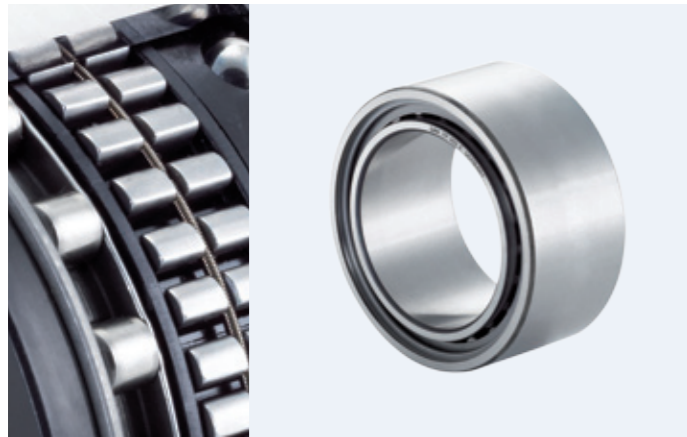

Components

Freewheel clutch insert element*	FE 400 M (meander spring) FE 400 Z (tension spring)
+ Raceways	Bearing steel, hardened and ground
inner ring	Press fit
outer ring	Press fit
+ Ball bearing	Integrated
+ Roller bearing	Integrated
- Lubrication	-
- Seal	-

* available with either freewheel clutch insert element FE 400 M (meander spring) or FE 400 Z (tension spring).

Characteristics

Width
27 mm

Operating temperature
max. 140°C
Higher temperatures on request

Lubrication

oil or grease lubrication (Pg. 60–61)
Delivered with corrosion protection.
Operative grease filling on request.

Installation

Installation tolerances
Shaft h5; hub H6

Mating parts

Hardening and grinding of the mating parts is not necessary.
Thoroughly clean (grease free) the mating parts in the vicinity of the freewheel clutch as well as the freewheel clutch's rings before making the press fit.

Bearing

The freewheel clutch includes ball and roller bearings.
Additional external bearing support is not necessary.

Press fit pressure

Press fit pressure must not be applied to the balls.

Clamping direction

The arrow on the inner ring designates the inner ring's clamping direction.

Data

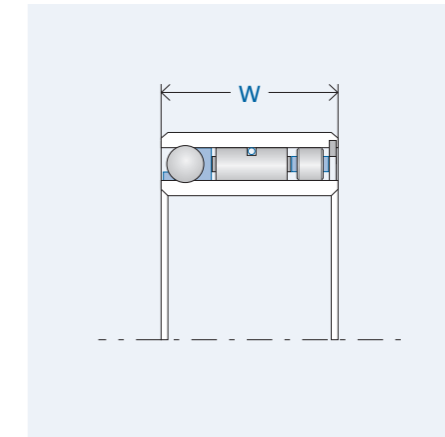
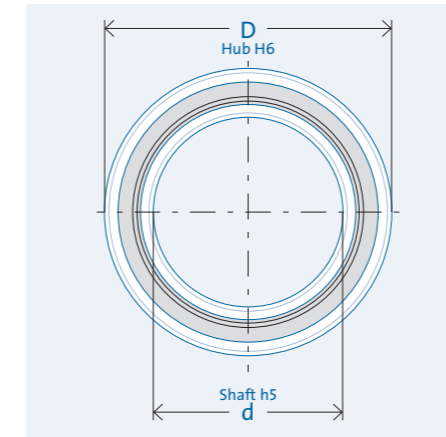

Drawing legend

- d = inner diameter
- D = outer diameter
- W = width
- T = torque
- n = rotation speed
- C = load capacity

Designation	d [mm]	D [mm]	W [mm]	T _{nom} [Nm]	n _{max} [rpm]	C _{dyn.} [N]	C _{stat.} [N]	Weight [kg]	Item no.
FP 422 M	10	26	27	60	10,100	6,013	4,380	0.07	300655
FP 422 Z	10	26	27	53	10,100	6,013	4,380	0.07	300656
FP 427 M	15	31	27	94	7,400	7,679	6,397	0.08	300663
FP 427 Z	15	31	27	84	7,400	7,679	6,397	0.08	300664
FP 432 M	20	36	27	133	5,900	8,104	7,241	0.10	300669
FP 432 Z	20	36	27	121	5,900	8,104	7,241	0.10	300670
FP 437 M	25	41	27	176	4,800	9,201	8,142	0.12	300673
FP 437 Z	25	41	27	160	4,800	9,201	8,142	0.12	300674
FP 442 M	30	46	27	223	4,200	10,247	10,708	0.14	300679
FP 442 Z	30	46	27	208	4,200	10,247	10,708	0.14	300680
FP 448 M	35	53	27	286	4,300	11,642	13,440	0.19	306522
FP 448 Z	35	53	27	262	4,300	11,642	13,440	0.19	306523
FP 453 M	40	58	27	343	3,400	11,417	13,577	0.21	300683
FP 453 Z	40	58	27	314	3,400	11,417	13,577	0.21	300684
FP 463 M	50	68	27	461	2,900	13,070	17,063	0.25	300685
FP 463 Z	50	68	27	428	2,900	13,070	17,063	0.25	300687
FP 473 M	60	78	27	588	2,500	14,128	19,896	0.30	300691
FP 473 Z	60	78	27	543	2,500	14,128	19,896	0.30	300693

The specified nominal torque is based on sufficient stiffness of mating parts (Pg. 22).
Rotation speed n = insert element's inherent speed (Pg. 57)

Complete Freewheel Clutch Unit FN

with keyway (IR)



Characteristics

Width
27 mm

Operating temperature
max. 140°C
Higher temperatures on request

Lubrication

oil or grease lubrication (Pg. 60–61)
Delivered with corrosion protection.
Operative grease filling on request.

Installation

Installation tolerances
Shaft js6 (k5); hub H6

Mating parts

Hardening and grinding of the mating parts is not necessary.
Thoroughly clean (grease free) the mating parts in the vicinity of the freewheel clutch as well as the freewheel clutch's rings before making the press fit.

Bearing

The freewheel clutch includes ball and roller bearings.
Additional external bearing support is not necessary.

Press fit pressure

Press fit pressure must not be applied to the balls.

Clamping direction

The arrow on the inner ring designates the inner ring's clamping direction.

Components

Freewheel clutch insert element*	FE 400 M (meander spring) FE 400 Z (tension spring)
+ Raceways	Bearing steel, hardened and ground
inner ring	Keyway per DIN 6885, Sheet 1 Tolerance: P9 with back clearance
outer ring	Press fit
+ Ball bearing	Integrated
+ Roller bearing	RL 400
- Lubrication	-
- Seal	-

* available with either freewheel clutch insert element FE 400 M (meander spring) or FE 400 Z (tension spring).

Data

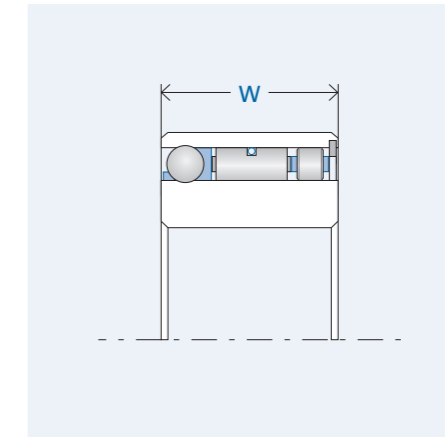
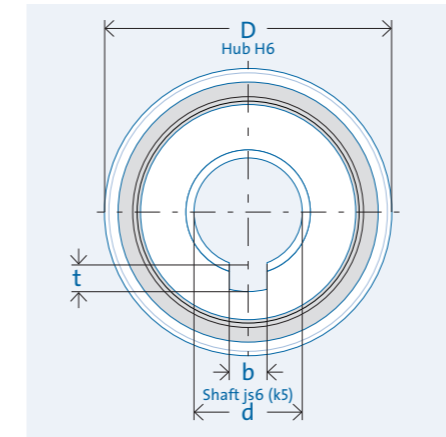

Drawing legend

- d = inner diameter
- D = outer diameter
- W = width
- T = torque
- n = rotation speed
- C = load capacity
- b = keyway width
- t = keyway depth

Designation	d [mm]	D [mm]	W [mm]	T _{nom} [Nm]	n _{max} [rpm]	C _{dyn.} [N]	C _{stat.} [N]	Weight [kg]	b [mm]	t [mm]	Item no.
FN 437 M	15	41	27	176	4,800	8,962	8,661	0.19	15	2.3	300706
FN 437 Z	15	41	27	160	4,800	8,962	8,661	0.19	15	2.3	300707
FN 442 M	20	46	27	223	4,200	10,247	10,708	0.22	20	2.8	300712
FN 442 Z	20	46	27	208	4,200	10,247	10,708	0.22	20	2.8	300714
FN 453 M	25	58	27	343	3,400	11,417	13,577	0.36	25	3.3	300718
FN 453 Z	25	58	27	314	3,400	11,417	13,577	0.36	25	3.3	300719
FN 459 M	30	64	27	411	3,000	12,691	16,320	0.43	30	3.3	300726
FN 459 Z	30	64	27	381	3,000	12,691	16,320	0.43	30	3.3	300728
FN 463 M	35	68	27	461	2,900	13,070	17,063	0.47	35	3.3	306526
FN 463 Z	35	68	27	427	2,900	13,070	17,063	0.47	35	3.3	306527
FN 470 M	40	75	27	550	2,600	14,050	19,840	0.54	40	3.3	300731
FN 470 Z	40	75	27	509	2,600	14,050	19,840	0.54	40	3.3	300733
FN 473 M	45	78	27	588	2,500	14,128	19,896	0.58	45	3.8	306530
FN 473 Z	45	78	27	544	2,500	14,128	19,896	0.58	45	3.8	306531

The specified nominal torque is based on sufficient stiffness of mating parts (Pg. 22) and refers to the integrated insert element, not the key way.
Rotation speed n = insert element's inherent speed (Pg. 57)

Ball Bearing Freewheel Clutch Unit FK (2RS)



for press fit (IR and OR)



Characteristics

Dimensions

Dimensions in accordance with bearing series 62 (DIN 625)

Width

12 / 14 / 15 / 16 / 17 / 18 mm

Operating temperature

max. 140°C

Higher temperatures on request
max. 110°C (design 2RS with RS seals)

Lubrication

Series FK 2RS with seals

Operative lifetime grease lubrication

Series FK without seal discs

Oil or grease lubrication (Pg. 60–61)
Delivered with corrosion protection.

Installation

Installation tolerances

Shaft n6; hub N7

Mating parts

Hardening and grinding of the mating parts is not necessary. Thoroughly clean (grease free) the mating parts in the vicinity of the freewheel clutch as well as the freewheel clutch's rings before making the press fit.

Bearing

The freewheel clutch includes a ball bearing. Additional external bearing support is not necessary.

Press fit pressure

Press fit pressure must not be applied to the balls.

Clamping direction

The arrow on the inner ring designates the inner ring's clamping direction.

Seals*

The RS Seals reliably seal out grease and dust but are not suitable to protect against permanent higher liquid levels.

Series FK 6203-RS has an RS seal on one side only (RS Seal on the freewheel side).

Data

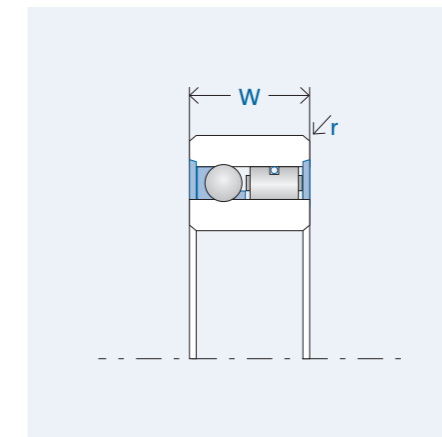
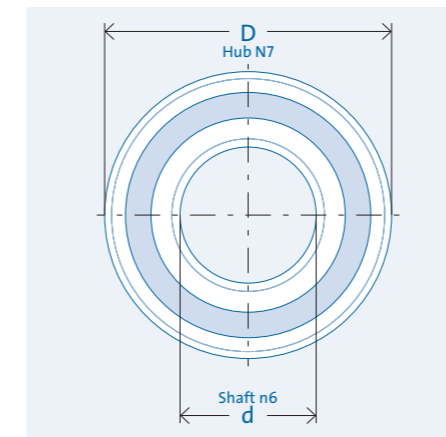

Drawing legend

- d = inner diameter
- D = outer diameter
- W = width
- r = edge radius
- T = torque
- n = rotation speed
- C = load capacity

Components

Freewheel clutch insert element FE 400 Z2

+ Raceways Bearing steel, hardened and ground
inner ring Press fit
outer ring Press fit

+ Ball bearing Integrated

- Roller bearing -

+ Lubrication Lifetime grease lubrication*

+ Seal RS seals*

* Series FK 2RS (with RS seals)

Designation	d [mm]	D [mm]	W [mm]	T _{nom} [Nm]	n _{max} [rpm]	C _{dyn.} [N]	C _{stat.} [N]	r [mm]	Weight [kg]	Item no.
FK 6203	17	40	12	53	10,800	6,245	3,441	1.0	0.07	301065
FK 6203-RS	17	40	12	53	3,700	6,245	3,441	1.0	0.07	301079
FK 6204	20	47	14	60	7,500	6,869	4,268	1.5	0.12	301068
FK 6204-2RS	20	47	14	60	3,200	6,869	4,268	1.5	0.12	301087
FK 6205	25	52	15	104	5,400	7,448	5,146	1.5	0.15	301070
FK 6205-2RS	25	52	15	104	2,800	7,448	5,146	1.5	0.15	301092
FK 6206	30	62	16	148	5,100	7,859	6,066	1.5	0.23	301074
FK 6206-2RS	30	62	16	148	2,400	7,859	6,066	1.5	0.23	301103
FK 6207	35	72	17	265	3,700	8,902	7,819	2.7	0.34	301077
FK 6207-2RS	35	72	17	265	1,900	8,902	7,819	2.7	0.34	301108
FK 6208	40	80	18	267	3,700	8,902	7,752	2.7	0.45	301078
FK 6208-2RS	40	80	18	267	1,900	8,902	7,752	2.7	0.45	301110
FK 6304-2RS	20	52	15	104	2,800	7,448	5,146	1.5	0.17	301098

All specifications for series FK 2RS (with seals) and series FK (without seals)

The specified nominal torque is based on sufficient stiffness of mating parts (Pg. 22).

Rotation speed n for series FK (without seals) = assembly unit's inherent speed (Pg. 57)

Rotation speed n for series FK 2RS (with seals) = speed difference of mating parts.

Ball Bearing Freewheel Clutch Unit FKN (2RS)



with keyway (IR)



Characteristics

Dimensions
Dimensions per bearing series 62 (DIN 625)

Width
12 / 14 / 15 / 16 / 17 / 18 mm

Operating temperature
max. 140°C
Higher temperatures on request
max. 110°C (design 2RS with RS seals)

Lubrication

Series FKN 2RS with seals
Operative lifetime grease lubrication

Series FKN without seals
Oil or grease lubrication (Pg. 60–61)
Delivered with corrosion protection.

Installation

Installation tolerances
Shaft n6; hub N7

Mating parts
Hardening and grinding of the mating parts is not necessary.
Thoroughly clean (grease free) the mating parts in the vicinity of the freewheel clutch as well as the freewheel clutch's rings before making the press fit.

Bearing
The freewheel clutch includes a ball bearing.
Additional external bearing support is not necessary.

Press fit pressure
Press fit pressure must not be applied to the balls.

Clamping direction
The arrow on the inner ring designates the inner ring's clamping direction.

Seals*
The employed RS seal reliably seal out grease and dust but are not suitable protection against the presence of liquids.

Series FKN 6203-RS has a RS seal on one side only (RS seal on the freewheel side).

Data

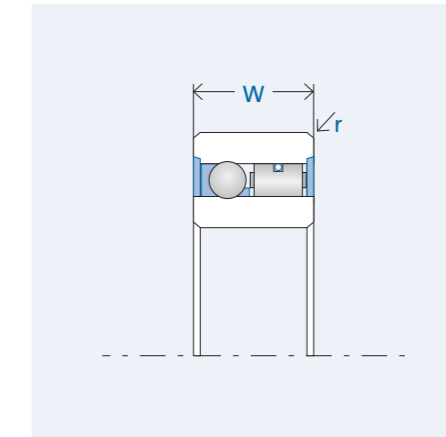
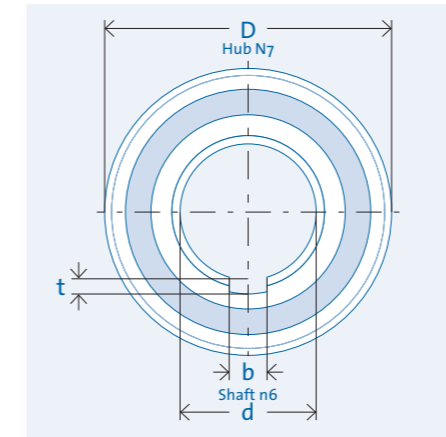

Drawing legend

- d = inner diameter
- D = outer diameter
- W = width
- r = edge radius
- b = keyway width IR
- t = keyway depth IR
- T = torque
- n = rotation speed
- C = load capacity

Components

Freewheel clutch insert element	FE 400 Z2
+ Raceways inner ring	Bearing steel, hardened and polished Keyway per DIN 6885, Sheet 3 (Sizes 6203-6206) Keyway per DIN 6885, Sheet 1 (Sizes 6207-6208) Tolerance: P9 with back clearance Press fit
outer ring	Press fit
+ Ball bearing	Integrated
- Roller bearing -	
+ Lubrication	Lifetime grease lubrication*
+ Seal	RS seals*

* Series FKN 2RS (with RS seals)

Designation	d [mm]	D [mm]	W [mm]	r [mm]	b [mm]	t [mm]	T _{nom} [Nm]	n _{max} [rpm]	C _{dyn.} [N]	C _{stat.} [N]	Weight [kg]	Item no.
FKN 6203	17	40	12	1	5	12	53	10,800	6,245	3,441	0.07	301112
FKN 6203-RS	17	40	12	1	5	1.2	53	3,700	6,245	3,441	0.07	301114
FKN 6204	20	47	14	1.5	6	1.6	60	7,500	6,869	4,268	0.12	301120
FKN 6204-2RS	20	47	14	1.5	6	1.6	60	3,200	6,869	4,268	0.12	301125
FKN 6205	25	52	15	1.5	8	2	104	5,400	7,448	5,146	0.15	301131
FKN 6205-2RS	25	52	15	1.5	8	2	104	2,800	7,448	5,146	0.15	301130
FKN 6206	30	62	16	1.5	8	2	148	5,100	7,859	6,066	0.23	301145
FKN 6206-2RS	30	62	16	1.5	8	2	148	2,400	7,859	6,066	0.23	301143
FKN 6207	35	72	17	1.5	10	3.3	265	3,700	8,902	7,819	0.33	301156
FKN 6207-2RS	35	72	17	1.5	10	3.3	265	1,900	8,902	7,819	0.33	301158
FKN 6208	40	80	18	1.5	12	3.3	267	3,700	8,902	7,752	0.45	301161
FKN 6208-2RS	40	80	18	1.5	12	3.3	267	1,900	8,902	7,752	0.45	301163

All specifications for series FKN 2RS (with seals) and series FKN (without seals)
The specified nominal torque is based on sufficient stiffness of mating parts (Pg. 22)
and refers to the integrated insert element, not the key way.
Rotation speed n for series FKN (without seals) = insert element's inherent speed (Pg. 57)
Rotation speed n for series FKN 2RS (with seals) = speed difference of mating parts.

Ball Bearing Freewheel Clutch Unit FKNN (2RS)



with keyway (IR) and rectangular groove (OR)

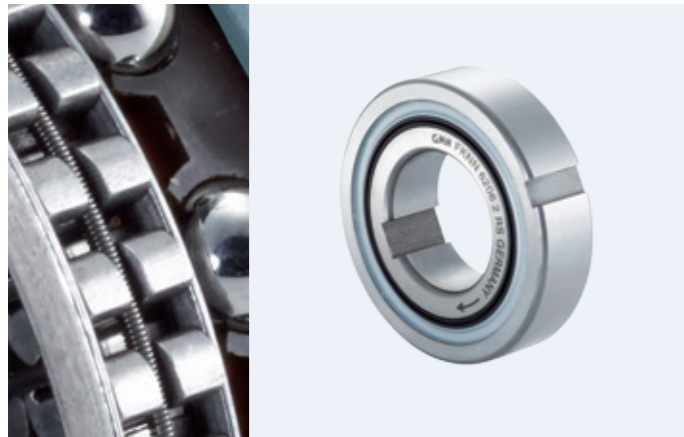

Characteristics

Dimensions
Dimensions in accordance with bearing series 62 (DIN 625)

Width
12 / 14 / 15 / 16 / 18 mm

Operating temperature
max. 140°C
Higher temperatures on request
max. 110°C (design 2RS with RS seals)

Lubrication

Series FKNN 2RS with seals
Operative lifetime grease lubrication

Series FKNN without seals
Oil or grease lubrication (Pg. 60–61)
Delivered with corrosion protection.

Installation

Installation tolerances
Shaft n6; hub N7

Mating parts
Hardening and grinding of the mating parts is not necessary.
Thoroughly clean (grease free) the mating parts in the vicinity of the freewheel clutch as well as the freewheel clutch's rings before making the press fit.

Bearing
The freewheel clutch is bearing mounted.
Additional external bearing support is not necessary.

Press fit pressure
Press fit pressure must not be applied to the balls.

Clamping direction
The arrow on the inner ring designates the inner ring's clamping direction.

Seals*
The employed RS seals reliably seal out grease and dust but are not suitable protection against the presence of liquids.

Series FKNN 6203-RS has a RS seal disc on one side only (RS seal on the freewheel side).

Data

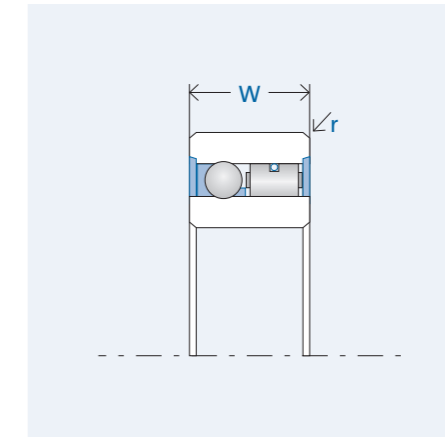
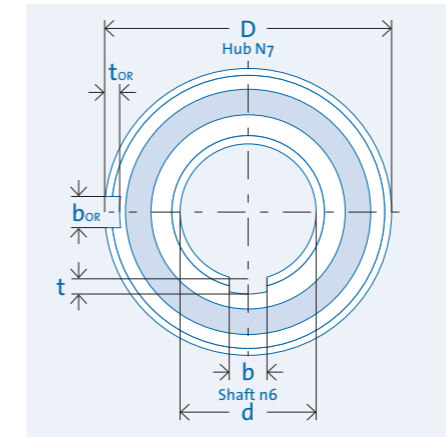

Drawing legend

- d = inner diameter
- D = outer diameter
- W = width
- r = edge radius
- b = keyway width
- t = keyway depth
- b_{OR} = rectangular groove width
- t_{OR} = rectangular groove depth
- T = torque
- n = rotation speed
- C = load capacity

Components

Freewheel clutch insert element	FE 400 Z2
+ Raceways inner ring	Bearing steel, hardened and ground Keyway per DIN 6885, Sheet 3 (Sizes 6203-6206) Keyway per DIN 6885, Sheet 1 (Sizes 6207-6208) Tolerance: P9 with back clearance Rectangular groove
outer ring	
+ Ball bearing	Integrated
- Roller bearing -	
+ Lubrication	Lifetime grease lubrication*
+ Seal	RS seals*

* Series FKNN 2RS (with RS seals)

Designation	d [mm]	D [mm]	W [mm]	r [mm]	b [mm]	t [mm]	b _{OR} [mm]	t _{OR} [mm]	T _{nom} [Nm]	n _{max} [rpm]	C _{dyn.} [N]	C _{stat.} [N]	Weight [kg]	Item no.
FKNN 6203	17	40	12	1	5	1.2	2	1	53	10,800	6,245	3,441	0.07	305989
FKNN 6203-RS	17	40	12	1	5	1.2	2	1	53	3,700	6,245	3,441	0.07	305990
FKNN 6204	20	47	14	1.5	6	1.6	3	1,5	60	7,500	6,869	4,268	0.12	305992
FKNN 6204-2RS	20	47	14	1.5	6	1.6	3	1,5	60	3,200	6,869	4,268	0.12	305993
FKNN 6205	25	52	15	1.5	8	2	6	2	104	5,400	7,448	5,146	0.14	305995
FKNN 6205-2RS	25	52	15	1.5	8	2	6	2	104	2,800	7,448	5,146	0.14	305996
FKNN 6206	30	62	16	1.5	8	2	6	2	148	5,100	7,859	6,066	0.22	305998
FKNN 6206-2RS	30	62	16	1.5	8	2	6	2	148	2,400	7,859	6,066	0.22	305999
FKNN 6028	40	80	18	1.5	12	3.3	10	3	267	3,700	8,902	7,752	0.44	306004
FKNN 6208-2RS	40	80	18	1.5	12	3.3	10	3	267	1,900	8,902	7,752	0.44	306005
FKNN 6304-2RS	20	52	15	1.5	6	2	6	2	104	2,800	7,448	5,146	0.15	306137

All specifications for series FKNN 2RS (with seals) and series FKNN (without seals)
The specified nominal torque is based on sufficient stiffness of mating parts (Pg. 22)
and refers to the integrated insert element, not the key way.
Rotation speed n for series FKNN (without seals) = insert element's inherent speed (Pg. 57)
Rotation speed n for series FKNN 2RS (with seals) = speed difference of mating parts.

Freewheel Clutch Insert Element FR

with rings



Components

Freewheel clutch insert element*	FE 400 M (meander spring) FE 400 Z (tension spring)
+ Raceways	Bearing steel, hardened and ground
inner ring	Press fit
outer ring	Press fit
- Ball bearing	-
- Roller bearing	-
- Lubrication	-
- Seal	-

* available with either freewheel clutch insert element FE 400 M (meander spring) or FE 400 Z (tension spring).

Characteristics

Width
12 mm

Operating temperature
max. 140°C
Higher temperatures on request

Lubrication

Oil or grease lubrication (Pg. 60–61)
Delivered with corrosion protection.
Operative grease filling on request.

Installation

Installation tolerances
Shaft h5; hub H6

Constraints

The freewheel clutch insert element requires axial constraints on both sides.

Mating parts

Hardening and grinding of the mating parts is not necessary. Thoroughly clean (grease free) the mating parts in the vicinity of the freewheel clutch as well as the freewheel clutch's rings before making the press fit.

Bearing

Freewheel clutch insert elements are not self-centering. External bearing support to define the gap between mating parts (inner and outer rings) is necessary.

Data

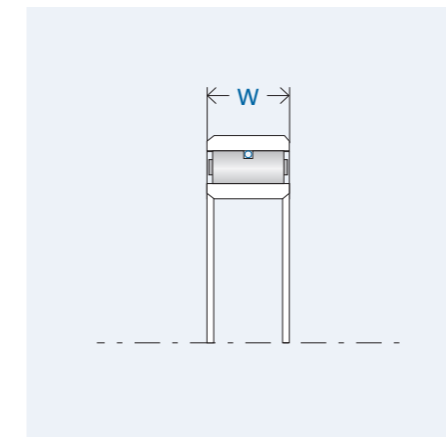
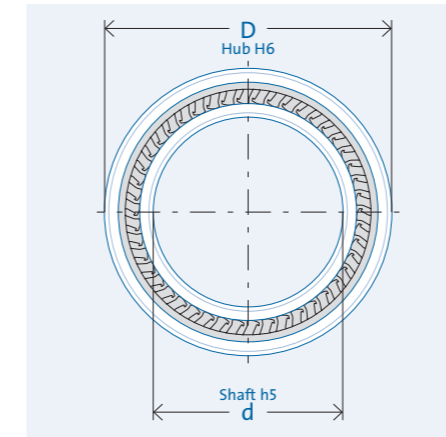

Drawing legend

d = inner diameter
D = outer diameter
W = width
T = torque
n = rotation speed

Designation	d [mm]	D [mm]	W [mm]	T _{nom} [Nm]	n _{max} [rpm]	Weight [kg]	Item no.
FR 422 M	10	26	12	60	10,100	0.03	300587
FR 422 Z	10	26	12	53	10,100	0.03	300588
FR 427 M	15	31	12	92	7,400	0.04	300591
FR 427 Z	15	31	12	83	7,400	0.04	300592
FR 432 M	20	36	12	128	5,900	0.05	300593
FR 432 Z	20	36	12	117	5,900	0.05	300594
FR 437 M	25	41	12	169	4,800	0.06	300595
FR 437 Z	25	41	12	154	4,800	0.06	300598
FR 442 M	30	46	12	212	4,200	0.07	300599
FR 442 Z	30	46	12	198	4,200	0.07	300600
FR 448 M	35	53	12	272	4,300	0.09	300602
FR 448 Z	35	53	12	248	4,300	0.09	300603
FR 453 M	40	58	12	321	3,400	0.10	300605
FR 453 Z	40	58	12	294	3,400	0.10	300606
FR 463 M	50	68	12	427	2,900	0.12	300608
FR 463 Z	50	68	12	394	2,900	0.12	300610
FR 473 M	60	78	12	539	2,500	0.14	300611
FR 473 Z	60	78	12	496	2,500	0.14	300613

The specified nominal torque is based on sufficient stiffness of mating parts (Pg. 22).
Rotation speed n = insert element's inherent speed (Pg. 57)

Freewheel Clutch Insert Element FRN

with rings and keyway (IR)



Components

Freewheel clutch insert element*	FE 400 M (meander spring) FE 400 Z (tension spring)
+ Raceways	Bearing steel, hardened and ground
inner ring	Keyway per DIN 6885, Sheet 1 Tolerance: P9 with back clearance
outer ring	Press fit
- Ball bearing	-
- Roller bearing	-
- Lubrication	-
- Seal	-

* available with either freewheel clutch insert element FE 400 M (meander spring) or FE 400 Z (tension spring).

Characteristics

Width
12 mm

Operating temperature
max. 140°C
Higher temperatures on request

Lubrication

Oil or grease lubrication (Pg. 60–61)
Delivered with corrosion protection.
Operative grease filling on request.

Installation

Installation tolerances
Shaft js6 (k5); hub H6

Constraints

The freewheel clutch insert element requires axial constraints on both sides.

Mating parts

Hardening and grinding of the mating parts is not necessary. Thoroughly clean (grease free) the mating parts in the vicinity of the freewheel clutch as well as the freewheel clutch's rings before making the press fit.

Bearing

Freewheel clutch insert elements are not self-centering. External bearing support to define the gap between mating parts (inner and outer rings) is necessary.

Data

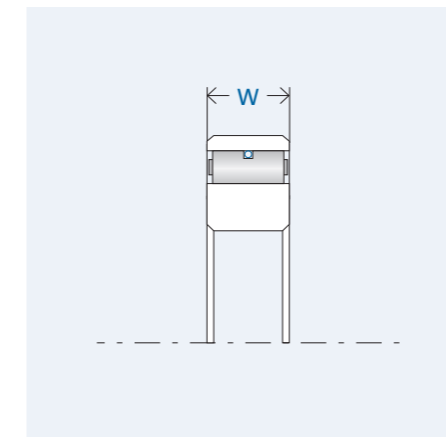
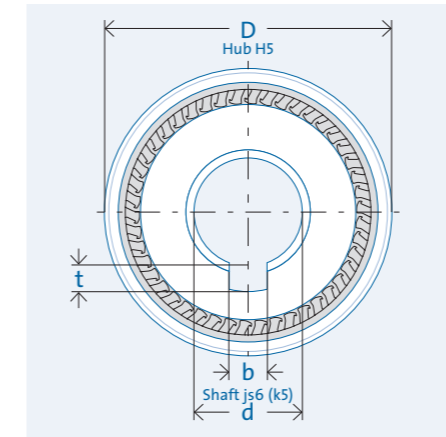

Drawing legend

- d = inner diameter
- D = outer diameter
- W = width
- T = torque
- n = rotation speed
- b = keyway width
- t = keyway depth

Designation	d [mm]	D [mm]	W [mm]	T _{nom} [N]	n _{max} [rpm]	Weight [kg]	b [mm]	t [mm]	Item no.
FRN 427 M	10	31	12	92	7,400	0.05	3	1.4	300625
FRN 427 Z	10	31	12	83	7,400	0.05	3	1.4	300626
FRN 432 M	12	36	12	128	5,900	0.07	4	1.8	300628
FRN 432 Z	12	36	12	117	5,900	0.07	4	1.8	300629
FRN 437 M	15	41	12	169	4,800	0.08	5	2.3	300630
FRN 437 Z	15	41	12	154	4,800	0.08	5	2.3	300631
FRN 442 M	20	46	12	212	4,200	0.10	6	2.8	300633
FRN 442 Z	20	46	12	198	4,200	0.10	6	2.8	300634
FRN 453 M	25	58	12	321	3,400	0.17	8	3.3	300636
FRN 453 Z	25	58	12	294	3,400	0.17	8	3.3	300637
FRN 459 M	30	64	12	332	3,000	0.20	8	3.3	300639
FRN 459 Z	30	64	12	353	3,000	0.20	8	3.3	300640
FRN 463 M	35	68	12	427	2,900	0.21	10	3.3	300641
FRN 463 Z	35	68	12	393	2,900	0.21	10	3.3	300642
FRN 470 M	40	75	12	506	2,600	0.25	12	3.3	300644
FRN 470 Z	40	75	12	466	2,600	0.25	12	3.3	300645
FRN 473 M	45	78	12	539	2,500	0.26	14	3.8	300647
FRN 473 Z	45	78	12	496	2,500	0.26	14	3.8	300649

The specified nominal torque is based on sufficient stiffness of mating parts (Pg. 22) and refers to the integrated insert element, not the key way. Rotation speed n = insert element's inherent speed (Pg. 57)

Insert Element FE 400 Z

with tension spring



Components

Freewheel	Insert element FE 400 Z
· Spring	Tension spring (Z)
· Cage	Stamped steel / plastic (PA)
· Sprags	Hardened bearing steel
	Start gap height $h_0 = 4$ mm

- Thrust rings	-
- Ball bearing	-
- Roller bearing	-
- Lubrication	-
- Seal	-

Characteristics

Installed width
12 mm

Operating temperature
max. 140°C
Higher temperatures on request

Indexing frequency
max. 10 Hz

Lubrication

Oil or grease lubrication (Pg. 60–61)
Delivered with corrosion protection.
Pre-greased on request.

Installation

Installation tolerances
Shaft h5; hub H6

Inner ring/shaft
steel, HRC 60⁺⁴ (HV 700⁺¹⁰⁰); Ehd ≥ 1.3 mm; Rz ≤ 2.5 μm

Outer ring/housing
steel, HRC 60⁺⁴ (HV 700⁺¹⁰⁰); Ehd ≥ 1.3 mm; Rz ≤ 2.5 μm

Constraints

The freewheel clutch insert element requires axial constraints on both sides.

Mating parts

Hardening and grinding of the mating parts is necessary. Chamfered shafts and hubs ease installation (Pg. 58).

Bearing

Freewheel clutch insert elements are not self-centering. External bearing support to define the gap between mating parts (shaft and housing) is necessary.

Data

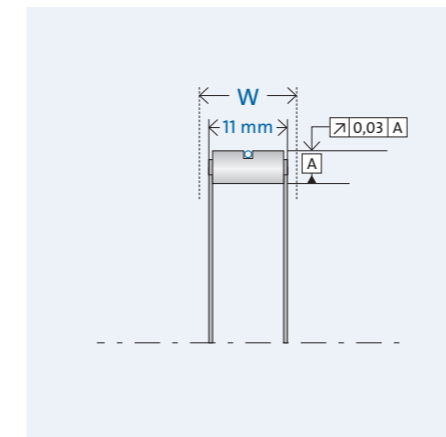
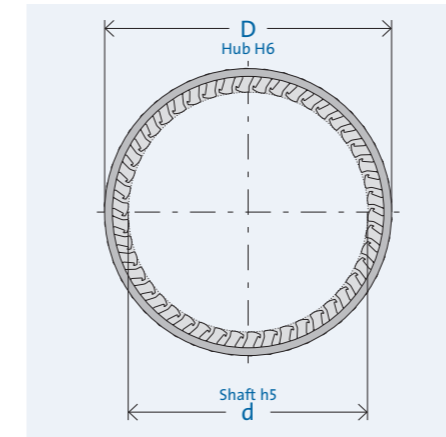

Drawing legend

d = inner diameter
D = outer diameter
W = width
T = torque
n = rotation speed

Designation	d [mm]	D [mm]	B [mm]	T _{nom} [Nm]	n _{max} [rpm]	Weight [kg]	Item no.
FE 412 Z	4	12	12	4	27,000	0.003	300393
FE 416 Z	8	16	12	16	19,200	0.006	300400
FE 420 Z	12	20	12	35	12,500	0.007	306041
FE 422 Z	14	22	12	53	10,100	0.008	300405
FE 423 Z	15	23	12	62	9,200	0.009	300411
FE 425 Z	17	25	12	72	8,100	0.011	300415
FE 427 Z	19	27	12	83	7,400	0.013	300422
FE 428 Z	20	28	12	93	7,500	0.013	300430
FE 430 Z	22	30	12	107	6,300	0.014	300435
FE 432 Z	24	32	12	117	5,900	0.016	300439
FE 433 Z	25	33	12	128	6,000	0.016	300445
FE 435 Z	27	35	12	143	5,100	0.017	300448
FE 437 Z	29	37	12	154	4,800	0.018	300455
FE 438 Z	30	38	12	166	4,900	0.019	300460
FE 442 Z	34	42	12	198	4,400	0.018	300463
FE 443 Z	35	43	12	207	4,300	0.022	300469
FE 448 Z	40	48	12	248	4,200	0.024	300478
FE 453 Z	45	53	12	293	3,400	0.022	300482
FE 455 Z	47	55	12	313	3,300	0.026	300487
FE 458 Z	50	58	12	344	3,100	0.029	300489
FE 459 Z	51	59	12	353	3,000	0.030	300494
FE 463 Z	55	63	12	393	2,900	0.032	300497
FE 468 Z	60	68	12	444	2,700	0.034	300501
FE 470 Z	62	70	12	465	2,600	0.035	300505
FE 473 Z	65	73	12	495	2,500	0.037	300508
FE 478 Z	70	78	12	548	2,600	0.039	300511
FE 488 Z	80	88	12	657	2,100	0.045	300514
FE 508 Z	100	108	12	889	1,700	0.055	300519
FE 528 Z	120	128	12	1,127	1,300	0.066	300522
FE 648 Z	240	248	12	2,673	800	0.131	300524

The specified nominal torque is based on sufficient stiffness of mating parts (Pg. 22).
Rotation speed n = insert element's inherent speed (Pg. 57)

Insert Element FE 400 M

with meander spring



Components

Freewheel	Insert element FE 400 M
· Spring	Meander spring (M)
· Cage	Stamped steel
· Sprags	Hardened bearing steel
	Start gap height $h_0 = 4$ mm

- Thrust rings -
- Ball bearing -
- Roller bearing -
- Lubrication -
- Seal -

Characteristics

Installed width
12 mm

Operating temperature
max. 170°C

Indexing frequency
max. 60 Hz

Lubrication

Oil or grease lubrication (Pg. 60–61)
Delivered with corrosion protection.
Pre-greased on request.

Installation

Installation tolerances
Shaft h5; hub H6

Inner ring/shaft
steel, HRC 60⁺⁴ (HV 700⁺¹⁰⁰); Ehd ≥ 1.3 mm; Rz ≤ 2.5 μm

Outer ring/housing
steel, HRC 60⁺⁴ (HV 700⁺¹⁰⁰); Ehd ≥ 1.3 mm; Rz ≤ 2.5 μm

Constraints

The freewheel clutch insert element requires axial constraints on both sides.

Mating parts

Hardening and grinding of the mating parts is necessary.
Chamfered shafts and hubs ease installation (Pg. 58).

Bearing

Freewheel clutch insert elements are not self-centering.
External bearing support to define the gap between mating parts (Shaft and housing) is necessary.

Data

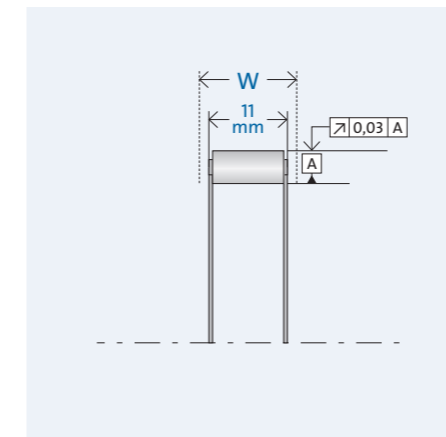
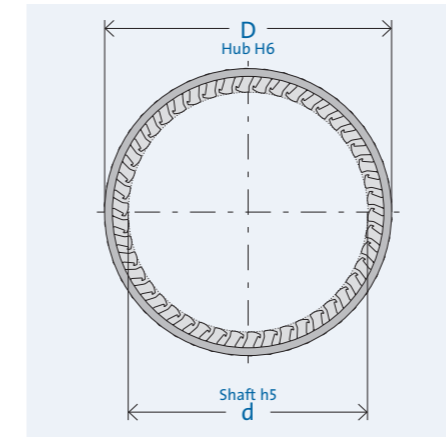

Drawing legend

- d = inner diameter
- D = outer diameter
- W = width
- T = torque
- n = rotation speed

Designation	d [mm]	D [mm]	W [mm]	T _{nom} [Nm]	n _{max} [rpm]	Weight [kg]	Item no.
FE 422 M	14	22	12	59	10,100	0.011	300404
FE 423 M	15	23	12	66	9,200	0.012	300409
FE 425 M	17	25	12	79	8,100	0.013	300414
FE 427 M	19	27	12	92	7,400	0.014	300421
FE 428 M	20	28	12	99	7,500	0.014	300428
FE 430 M	22	30	12	114	6,300	0.016	300434
FE 432 M	24	32	12	128	5,900	0.016	300438
FE 433 M	25	33	12	140	6,000	0.017	300444
FE 435 M	27	35	12	153	5,100	0.018	300447
FE 437 M	29	37	12	169	4,800	0.019	300451
FE 438 M	30	38	12	178	4,900	0.020	300459
FE 442 M	34	42	12	213	4,200	0.022	300462
FE 443 M	35	43	12	224	4,300	0.023	300468
FE 448 M	40	48	12	271	4,300	0.025	300473
FE 453 M	45	53	12	321	3,400	0.028	300481
FE 458 M	50	58	12	372	3,400	0.031	300488
FE 459 M	51	59	12	381	3,000	0.032	300492
FE 463 M	55	63	12	426	2,900	0.035	300495
FE 468 M	60	68	12	481	2,700	0.036	300500
FE 470 M	62	70	12	505	2,600	0.037	300503
FE 473 M	65	73	12	538	2,500	0.040	300506
FE 478 M	70	78	12	596	2,600	0.043	300510
FE 488 M	80	88	12	715	2,100	0.048	300515

The specified nominal torque is based on sufficient stiffness of mating parts. (Pg. 22)
Rotation speed n = insert element's inherent speed (Pg. 57)

Insert Element FE 400 Z2

in narrow design with tension spring

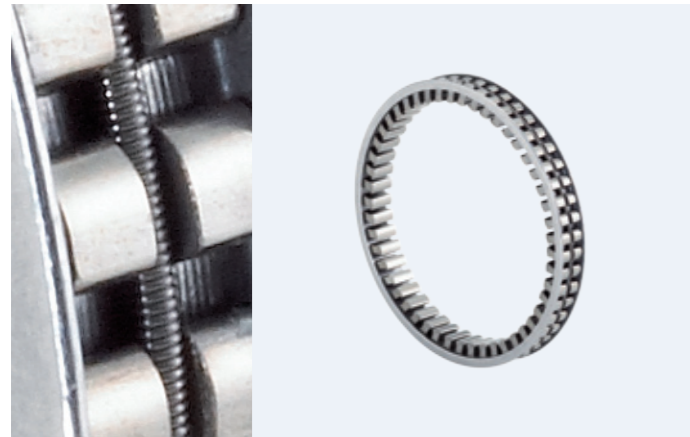

Characteristics

Installed width
7 mm

Operating temperature
max. 140°C
higher temperatures on request

Indexing frequency
max. 10 Hz

Lubrication

Oil or grease lubrication (Pg. 60–61)
Delivered with corrosion protection.
Pre-greased on request.

Installation

Installation tolerances
Shaft h5; hub H6

Inner ring/shaft
steel, HRC 60⁺⁴ (HV 700⁺¹⁰⁰); Ehd ≥ 1.3 mm; Rz ≤ 2.5 μm

Outer ring/housing
steel, HRC 60⁺⁴ (HV 700⁺¹⁰⁰); Ehd ≥ 1.3 mm; Rz ≤ 2.5 μm

Constraints

The freewheel clutch insert element requires axial constraints on both sides.

Mating parts

Hardening and grinding of the mating parts is necessary. Chamfered shafts and hubs ease installation (Pg. 58).

Bearing

Freewheel clutch insert elements are not self-centering. External bearing support to define the gap between mating parts (Shaft and housing) is necessary.

Data

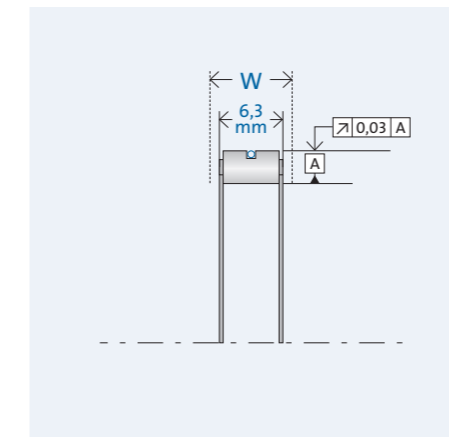
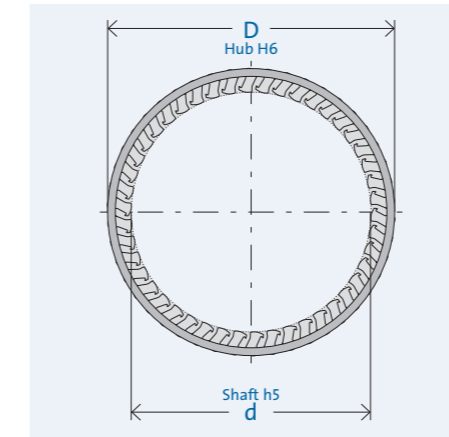

Drawing legend

d = inner diameter
D = outer diameter
W = width
T = torque
n = rotation speed

Designation	d [mm]	D [mm]	W [mm]	T _{nom} [Nm]	n _{max} [rpm]	Weight [kg]	Item no.
FE 410 Z2	2	10	7	0,6	52,600	0.001	300390
FE 412 Z2	4	12	7	2,5	40,900	0.002	300394
FE 413 Z2	5	13	7	4	34,900	0.003	300395
FE 414 Z2	6	14	7	6	31,200	0.003	300396
FE 416 Z2	8	16	7	10	27,200	0.004	300399
FE 418 Z2	10	18	7	16	18,900	0.005	300401
FE 422 Z2	14	22	7	30	13,200	0.006	300406
FE 423 Z2	15	23	7	40	13,200	0.006	300410
FE 425 Z2	17	25	7	43	10,600	0.007	300416
FE 428 Z2	20	28	7	55	9,700	0.008	300431
FE 433 Z2	25	33	7	78	7,700	0.010	300446
FE 437 Z2	29	37	7	97	6,100	0.011	300457
FE 438 Z2	30	38	7	105	6,400	0.011	300461
FE 442 Z2	34	42	7	125	5,400	0.012	300465
FE 443 Z2	35	43	7	131	5,600	0.013	300472
FE 448 Z2	40	48	7	156	5,500	0.014	300477
FE 453 Z2	45	53	7	185	4,400	0.016	300484
FE 458 Z2	50	58	7	216	4,400	0.017	300490
FE 463 Z2	55	63	7	246	3,700	0.019	300498
FE 468 Z2	60	68	7	277	3,500	0.020	300502

The specified nominal torque is based on sufficient stiffness of mating parts. (Pg. 22)
Rotation speed n = insert element's inherent speed (Pg. 57)

Insert Element FE 8000 Z

with tension spring



Components

Freewheel	Insert element FE 8000 Z
· Spring	Tension spring (Z)
· Cage	Stamped steel / drawn steel
· Sprags	Hardened bearing steel Start gap height $h_0 = 8.33$ mm

- Thrust rings	-
- Ball bearing	-
- Roller bearing	-
- Lubrication	-
- Seal	-

Characteristics

Width
16 / 19 / 25 mm

Operating temperature
max. 170°C

Indexing frequency
max. 5 Hz

Lubrication

Oil or grease lubrication (Pg. 60–61)
Delivered with corrosion protection.
Pre-greased on request.

Installation

Installation tolerances
Shaft h6; hub H6

Inner ring/shaft
steel, HRC 60⁺⁴ (HV 700⁺¹⁰⁰); Ehd ≥ 1.3 mm; Rz ≤ 2.5 μm

Outer ring/housing
steel, HRC 60⁺⁴ (HV 700⁺¹⁰⁰); Ehd ≥ 1.3 mm; Rz ≤ 2.5 μm

Constraints

The freewheel clutch insert element requires axial constraints on both sides.

Connecting parts

Hardening and grinding of the mating parts is necessary.
Chamfered shafts and hubs ease installation (Pg. 58).

Bearing

Freewheel clutch insert elements are not self-centering.
External bearing support to define the gap between mating parts (Shaft and housing) is necessary.

Data

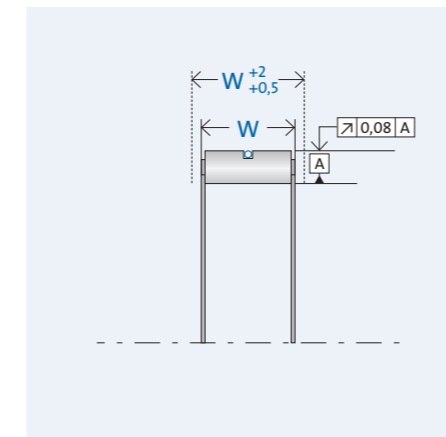
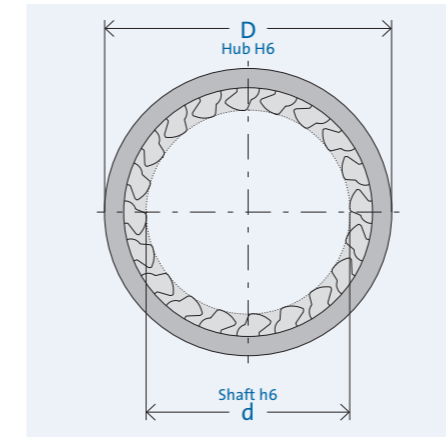

Drawing legend

d = inner diameter
D = outer diameter
W = width
T = torque

Designation	d [mm]	D [mm]	W [mm]	T _{nom} [Nm]	Weight [kg]	Item no.
FE 8038 Z 16	38.09	54.75	16	609	0.082	300527
FE 8038 Z 19	38.09	54.75	19	801	0.096	300528
FE 8040 Z 16	40.00	56.66	16	668	0.084	300530
FE 8040 Z 19	40.00	56.66	19	880	0.102	300531
FE 8044 Z 16	44.45	61.11	16	799	0.091	300535
FE 8044 Z 19	44.45	61.11	19	1,052	0.112	300536
FE 8049 Z 16	49.72	66.38	16	923	0.100	300538
FE 8049 Z 19	49.72	66.38	19	1,201	0.118	300539
FE 8050 Z 16	50.00	66.66	16	942	0.100	306637
FE 8050 Z 25	50.00	66.66	19	1,237	0.123	306638
FE 8054 Z 16	54.76	71.42	16	1,080	0.107	300541
FE 8054 Z 19	54.76	71.42	19	1,424	0.128	300542
FE 8054 Z 25	54.76	71.42	25	2,015	0.172	300543
FE 8060 Z 16	60.00	76.66	16	1,243	0.113	306639
FE 8060 Z 19	60.00	76.66	19	1,560	0.141	306640
FE 8060 Z 25	60.00	76.66	25	2,111	0.188	306641
FE 8072 Z 16	72.21	88.87	16	1,740	0.135	300548
FE 8072 Z 19	72.21	88.87	19	2,145	0.163	300549
FE 8072 Z 25	72.21	88.87	25	2,918	0.220	300550
FE 8079 Z 25	79.69	96.36	25	3,295	0.227	300551
FE 8080 Z 16	80.00	96.66	16	1,848	0.141	306642
FE 8080 Z 19	80.00	96.66	19	2,278	0.176	306643
FE 8080 Z 25	80.00	96.66	25	3,101	0.235	306644
FE 8083 Z 25	83.34	100.00	25	3,640	0.245	300553
FE 8100 Z 16	100.00	116.66	16	2,632	0.188	306645
FE 8100 Z 19	100.00	116.66	19	3,303	0.228	306646
FE 8100 Z 25	100.00	116.66	25	4,535	0.306	306647
FE 8103 Z 16	103.23	119.89	16	2,887	0.184	300556
FE 8103 Z 19	103.23	119.89	19	3,582	0.290	300557
FE 8103 Z 25	103.23	119.89	25	4,920	0.300	300558
FES 8123 Z 25	123.34	140.00	25	6,600	0.370	300561
FE 8123 Z 25	123.88	140.54	25	6,604	0.370	300559
FE 8126 Z 25	126.22	142.88	25	6,744	0.375	300562
FE 8140 Z 25	140.00	156.66	25	7,388	0.410	300565
FE 8150 Z 25	150.00	166.66	25	8,272	0.440	300567
FE 8160 Z 25	160.00	176.66	25	9,096	0.470	306344
FE 8180 Z 25	180.00	196.66	25	10,463	0.520	306274
FE 8220 Z 25	220.00	236.66	25	14,060	0.640	306148

The specified nominal torque is based on sufficient stiffness of mating parts. (Pg. 22)

Roller Bearings RL 400

Accessories

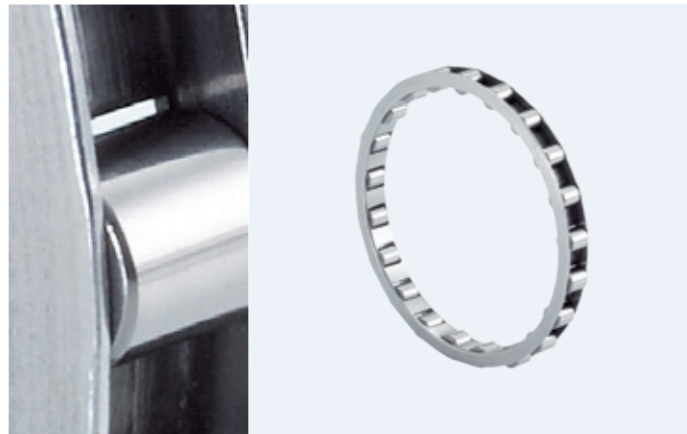

Components

Roller bearing RL 400
 · Cage Steel (RL 443 and RL 448 brass)
 · Rollers Hardened bearing steel
 Nominal diameter 4 mm

- Thrust rings -
- Ball bearing -
- Roller bearing -
- Lubrication -
- Seal -

Characteristics

Installed width:
6 mm

Operating temperature:
max. 170 °C
(RL 443 and RL 448 max. 150°C)

Lubrication

oil or grease lubrication (Pg. 60–61)
Delivered with corrosion protection.

Installation

Installation tolerances
Shaft h5; hub H6

Inner ring/shaft
steel, HRC 60⁺⁴ (HV 700⁺¹⁰⁰); Ehd ≥ 1.3 mm; Rz ≤ 2.5 μm

Outer ring/hub
steel, HRC 60⁺⁴ (HV 700⁺¹⁰⁰); Ehd ≥ 1.3 mm; Rz ≤ 2.5 μm

Constraints
The roller bearing requires axial constraints on both sides.
(collar, snap ring, C-clip, etc.).

Data

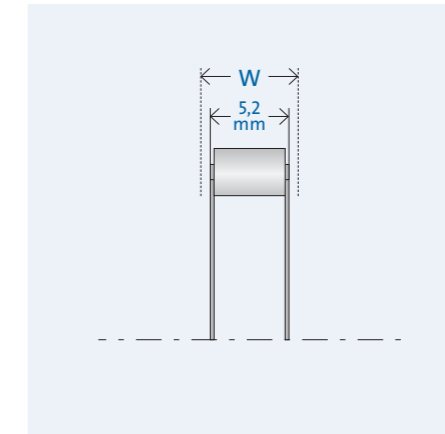
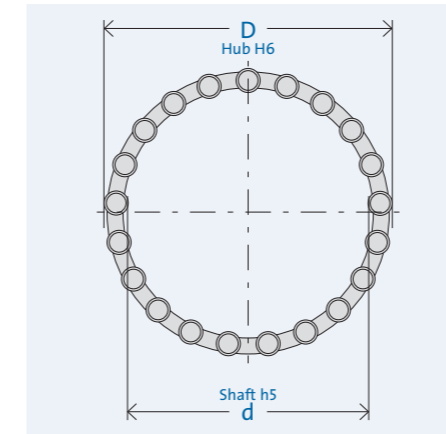

Drawing legend

- d = inner diameter
- D = outer diameter
- W = width
- n = rotation speed
- C = load capacity

Designation	d [mm]	D [mm]	W [mm]	C _{dyn.} [N]	C _{stat.} [N]	Oil n _{max} [rpm]	Grease n _{max} [rpm]	Item no.
RL 412 - 4	4	12	6	3,040	1,760	55,000	45,000	303071
RL 414 - 4	6	14	6	3,575	2,112	50,000	37,000	303131
RL 416 - 4	8	16	6	3,895	2,347	36,000	30,000	303091
RL 418 - 4	10	18	6	5,212	3,520	30,000	24,000	303111
RL 422 - 4	14	22	6	6,013	4,380	25,000	19,000	302652
RL 423 - 4	15	23	6	6,034	4,446	24,000	18,000	302914
RL 425 - 4	17	25	6	7,157	5,699	21,000	17,000	302954
RL 427 - 4	19	27	6	7,679	6,397	20,000	15,000	302672
RL 428 - 4	20	28	6	7,679	6,453	19,000	15,000	302853
RL 430 - 4	22	30	6	8,150	7,148	17,000	14,000	302974
RL 432 - 4	24	32	6	8,104	7,241	16,000	13,000	302692
RL 433 - 4	25	33	6	8,104	7,283	15,000	12,000	303169
RL 437 - 4	29	37	6	8,962	8,661	14,000	11,000	302712
RL 438 - 4	30	38	6	8,962	8,696	13,000	10,000	302993
RL 442 - 4	34	42	6	10,247	10,708	12,000	9,000	302732
RL 443 - 4	35	43	6	10,103	10,741	12,000	9,000	302873
RL 448 - 4	40	48	6	11,642	13,440	10,000	8,000	302893
RL 453 - 4	45	53	6	11,417	13,577	9,000	7,000	302752
RL 455 - 4	47	55	6	11,417	13,624	8,800	6,900	303012
RL 458 - 4	50	58	6	11,922	14,993	8,500	6,500	303031
RL 459 - 4	51	59	6	12,691	16,320	8,000	6,400	302773
RL 463 - 4	55	63	6	13,070	17,063	7,500	6,000	302793
RL 468 - 4	60	68	6	12,690	17,160	7,100	5,600	303151
RL 470 - 4	62	70	6	14,128	19,840	7,000	5,300	302813
RL 473 - 4	65	73	6	14,128	19,896	6,500	5,100	302833
RL 478 - 4	70	78	6	13,614	19,978	6,000	5,000	303051
RL 488 - 4	80	88	6	14,954	22,796	5,300	4,300	303183



Speed Limits

GMN Sprag Type Freewheel Clutches

- Speed limits
- Installation
- Tolerances
- Lubrication
- Service Life
- Applications

Theoretically, freewheel clutches have no speed limit during torque transfer. However, in idle and overrun operation the influence of centrifugal forces must be considered.

Series 400

The influence of centrifugal force

Spring force produces a torque F_s , which rotates the sprags and maintains constant friction contact with the mating parts. During rotation an opposing torque F_{zS} is imposed by centrifugal force.

When the opposing torque becomes greater than the torque created by the spring, the sprags will lift off the inner raceway. A reliable indexing process is no longer possible under these conditions. Decisive for this effect is the freewheel clutch insert element's inherent speed.

Lift-off speed

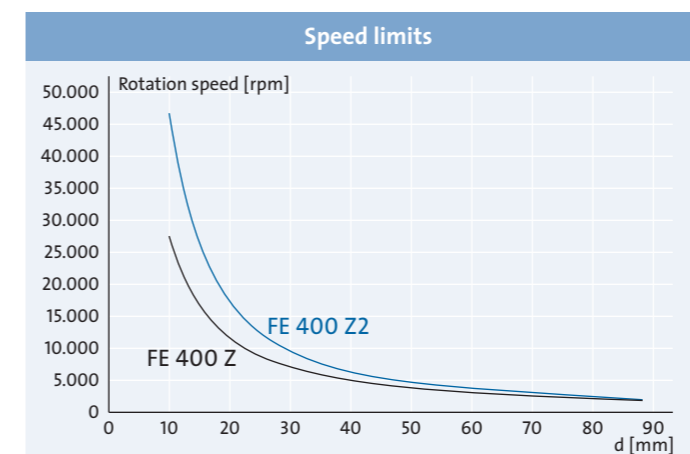
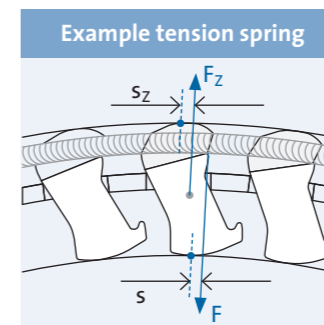
$$n = \frac{1}{2\pi} \sqrt{\frac{F_s}{mr \times s_z}}$$

Inherent speed of the freewheel clutch insert element

Inherent speed of the freewheel clutch insert element cannot be precisely predetermined because the freewheel clutch insert element is only in friction contact (sliding friction) with the mating parts. The freewheel clutch insert element will never rotate completely with the turning part, nor will it completely adhere to the standing part; a difference in speed will always occur.

The rotation speed limits provided in the diagram and size tables describe the inherent speed of freewheel clutch insert elements, they do not describe the maximum rotation speed of the shaft or hub. These values serve as a means to estimate whether centrifugal influences might have an effect.

For example, a critical operational state can be reached when the freewheel clutch is currently transferring torque and is then accelerated beyond the rotation speed limit. If the freewheel clutch is then disengaged, the sprags will lift off and lose contact with the raceway. A subsequent indexing process is only then possible if the rotation speed of the freewheel clutch insert element is once more reduced to below the lifting-off speed.

Freewheel-clutches with seals

The maximum permissible rotation speed of all sealed freewheel clutches is limited, not by centrifugal force but rather by the friction and heat generated at the seal. In these cases, the rotation speed limit specified in the size tables is the maximum permissible difference speed of mating parts.

Series 8000

The sprag profile for our 8000 series is a non lift-off design, i.e. at high rotation speeds centrifugal force will produce a pressing torque on the sprags because of their altered center of gravity (in comparison to series 400 sprags). Series 8000 freewheel clutch insert elements therefore have no rotation speed limit.

Installation

Freewheel clutch insert elements

FE 400 M / FE 400 Z / FE 400 Z2

GMN Freewheel clutch insert elements assembly units are built symmetrically and can be installed for a left or right clamping direction. All freewheel clutch insert elements are delivered on a packaging tube to protect them against damage. This tube can also be used as an installation aid.

If possible, mating parts should be chamfered to improve installation: installation chamfer for shaft and housing: 1 x 30°

FE 400 M

As an additional protective measure for the sprag, a rubber ring is stretched around the freewheel clutch insert element of type series FE 400 M.

Installation is performed by pushing the freewheel directly from the packing tube onto the shaft and into the hub. The freewheel can be completely pushed in after the rubber ring has been removed.

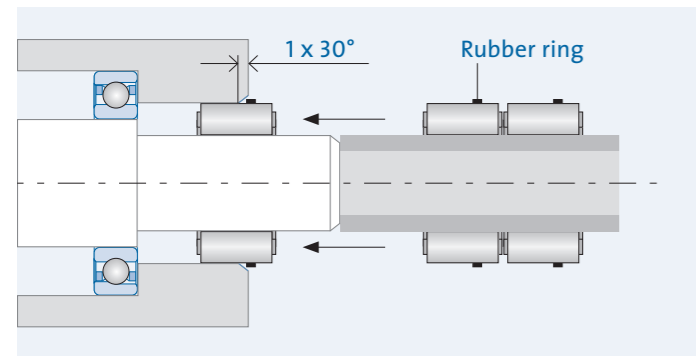

FE 400 Z installation with chamfer

The freewheel clutch is first positioned in the hub, the chamfered shaft can then be inserted with a turning motion in the idle direction.

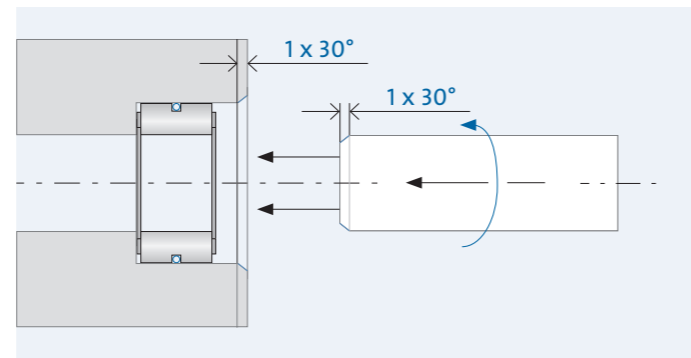

FE 400 Z installation without chamfer (tilted)

If the shaft is not chamfered, the freewheel clutch insert element should be pushed halfway onto the end of the shaft so that the sprags are slightly tilted.

This reduces the outer diameter of the freewheel clutch insert element enough to allow the shaft to be inserted together with the freewheel with a turning motion in the idle direction.

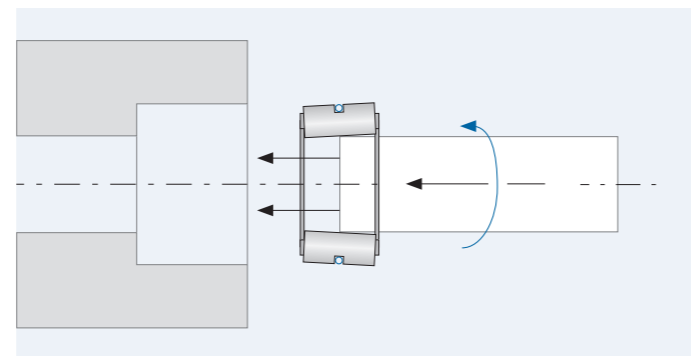

Tolerances

Tolerances

Shaft tolerances (excerpt from DIN EN ISO 286-2)

Shaft diameter d nominal dimension [mm]											
over to	1	3	6	10	18	30	50	80	120	180	250
h5 [µm]	0 -4	0 -5	0 -6	0 -8	0 -9	0 -11	0 -13	0 -15	0 -18	0 -20	0 -23
h6 [µm]	0 -6	0 -8	0 -9	0 -11	0 -13	0 -16	0 -19	0 -22	0 -25	0 -29	0 -32
js6 [µm]	+3 -3	+4 -4	+4.5 -4.5	+5.5 -5.5	+6.5 -6.5	+8 -8	+9.5 -9.5	+11 -11	+12.5 -12.5	+14.5 -14.5	16 -16
k5 [µm]	+4 0	+6 +1	+7 +1	+9 +1	+11 +2	+13 +2	+15 +2	+18 +3	+21 +3	+24 +4	+27 +4
n6 [µm]	+10 +4	+16 +8	+19 +10	+23 +12	+28 +15	+33 +17	+39 +20	+45 +23	+52 +27	+60 +31	+66 +34

Housing tolerances (excerpt from DIN EN ISO 286-2)

Bore diameter D nominal dimension [mm]											
over to	1	3	6	10	18	30	50	80	120	180	250
N7 [µm]	- -	-4 -16	-4 -19	-5 -23	-7 -28	-8 -33	-9 -39	-10 -45	-12 -52	-14 -60	-14 -66
H6 [µm]	- -	+8 0	+9 0	+11 0	+13 0	+16 0	+19 0	+22 0	+25 0	+29 0	+32 0

Lubrication

Providing freewheels with an adequate supply of GMN selected lubricants ensures correct performance and a long service life. GMN Freewheel clutches are suitable for oil or grease lubrication.

Corrosion protection

All GMN Freewheel clutches without seals are delivered with an effective corrosion protection and have to be greased by customer.

Lifetime pre-lubrication

GMN offers complete freewheel clutch units and ball bearing freewheel clutch units sealed on both sides with operative lifetime lubrication.

GMN Complete freewheel clutch units:

Series FPD, FND and RA

GMN Ball bearing freewheel clutch units:

Series FK 2RS, FKN 2RS, FKNN 2RS

The lubricant qualities and quantities selected by GMN ensure unrestricted capability for the freewheel clutch over its entire service lifetime.

Further lubrication (re-lubrication) for freewheel clutches with Lifetime pre-lubrication is not necessary.

Special solutions

Custom solutions for reliable lubrication under exceptional operating conditions, extreme operating temperatures or for vertical installation position applications are possible on request.

Notes:

An insufficient supply of lubricant, deviating lubricant qualities or the use of lubricants with friction reducing additives (such as MoS₂ or graphite, for example) can cause serious functional impairments or damage the freewheel clutches.

The use of lubricants from other manufacturers which have equivalent compositions is possible.

The compositions and characteristics of the specified lubricants can change due to technical advances and may necessitate re-testing with respect to lubricant qualification for GMN freewheel clutches.

All specifications reflect conditions as of the time of printing in June 2013.

Oil lubrication

Oil bath or oil mist lubrication is particularly well suited for high operating requirements with respect to rotation speeds and indexing frequencies.

Service life oil lubrication

GMN Complete freewheel clutch units:

Series FPD, FND and RA with GMN rubber seals

GMN Complete freewheel clutch units are sealed on both sides and have lifetime oil lubrication (Shell Tellus S2 MA 32) suitable for operating temperatures from 15 °C to 90 °C.

Other oil types for different temperature ranges are available on request.

Oil bath lubrication

Adequate pre-lubrication and re-lubrication is necessary for freewheel clutches in open housings. Such lubrication must accommodate the given freewheel clutch size and the structural characteristics of the mating parts.

For horizontal installation positions, the freewheel clutch should be about 1/3 submerged in the oil bath when at state of rest.

Oil mist lubrication

Hydraulic oils HM 10 and HM 32 are suitable for oil mist lubrication with respect to operating temperature.

Oil mist lubricated applications are based on a constant supply of sufficient fresh oil during operation.

Operating temperature	-65 to 100 °C	-35 to 160 °C	15 to 90 °C
Manufacturer	Klüber Isoflex PDP 38 LUBCON Turmofluid SF 48	Klübersynth GH 6 oils LUBCON Turmopoloil HT	Shell Tellus S2 MA 32
Oil type ¹⁾	Diester oil based	Polygl.oil based	mineral oil
Characteristics	synthetic long term oils	synthetic transm. and high temp. oils	high perform. hydraulic oils

¹⁾ Lubricants of the given oil type can be mixed. Mixing combinations of different oil types is not permissible.

Lubricant qualification

Selected common commercial motor oils are suitable for reliable re-lubrication.

HD motor oils SAE 10 W or SAE 30 conform to "API SF/CC" as well as "MIL-L46152B".

Grease lubrication

Economically efficient grease lubrication is sufficient for ordinary performance requirements.

Grease types are distinguished by special characteristics which, because of their specific composition, fundamentally make them differ from one another.

The selection of a suitable grease is to be made on the basis of specific operating conditions.

Lubricant qualification

GMN has chosen suitable grease types for differing operating conditions from DIN 51818 consistency classes NLGI 1 and NLGI 2.

Service life grease lubrication

GMN Ball bearing freewheel clutch units:

Series FK 2RS, FKN 2RS, FKNN 2RS with RS seals

The lubricating grease chosen by GMN for greasing sealed ball bearing freewheel clutches (Klüber ISOFLEX LDS 18 Special A) is intended for applications under normal operating conditions. Other grease types for different operational conditions are available on request.

Pre- and re-lubrication

Adequate pre-lubrication and re-lubrication are necessary for freewheel clutches in open housings. Such lubrication must accommodate the given freewheel clutches size and the structural characteristics of mating parts. All-over distribution of an adequate amount of grease (about 30–60% of the available volume in the freewheel) ensures an adequate lubricating effect.

Too much grease can result in functional failures at low temperatures.

Operating temperature	-50 to 120 °C	-40 to 180 °C	-40 to 200 °C	-40 to 260 °C
Manufacturer	Klüber Isoflex LDS 18 Special A LUBCON Turmogrease Highspeed L 252	Klüber Asonic GHY / HQ 72–102 LUBCON Turmogrease PU 703	Klübersynth BHP 72–102 LUBCON Turmogrease NBI 300 P	Klüber Barrierta L 55/2 LUBCON Turmotemp II/400 RS2
Base oil	Mineral oil Diester oil	Diester oil	Perfluoropolyether oil Diester oil	Perfluoropolyether oil
Thickener	Lithium soap	Polyurea	Polyurea, PTFE	PTFE
Characteristics	Dynamically light long-term lub. grease	Synthetic long-term lub. grease	High temperature long-term lub. grease	High temperature long-term lub. grease

Service Life Applications

Freewheel-clutch service life

GMN Freewheel clutches are the result of setting maximum demands on materials and processing in order to achieve the longest possible service life.

However, the basic functionality of freewheel clutches cause material stresses which result in a limit on service life.

Idle operation

The constant friction contact of sprags with mating parts during idle operation causes material wear which limits the service life of sprag type freewheel clutches.

Freewheel clutches with a tension spring offer outstanding operating conditions for applications with high idle operation rotation speed requirements (backstops, overrunning clutches).

Indexing operation

Torque-dependent distortion forces (Hertzian pressures) act on relevant freewheel clutch components during indexing operation and these lead to material fatigue over the long-term.

In particular, applications in which there are continuous high indexing frequencies can produce micro cracks and material chipping.

GMN has an analysis program which can project freewheel clutch service life under special consideration for indexing frequency and torque requirements.

The results of service life time calculations for specific application profiles are available on request.

Backstop



A Backstop application is where rotation is allowed in one direction and stopped in the opposite direction.

Application examples:

- Conveyor equipment
- Mixers
- High voltage switches
- Furniture industry
- Turnstiles and revolving doors
- Geared motors
- Winches
- Elevators
- Cranes
- Strap/belt tighteners
- Bucket conveyors
- Belt reversing locks
- Fans
- Automatic doors (subway)
- Fire damper flaps
- Aviation technology
- Roller plants
- Summer skiing
- etc.

Indexing clutch



A repeated drive and idle motion will be transformed step by step into rotary motion in a single direction.

Application examples:

- Paper processing (advance)
- Seeding machines
- Staplers (staples)
- Conveyor belts (drive)
- Ratchets
- Ratchet wrenches
- Roller advance
- Installation tools
- Automation technology
- etc.

Overrunning clutch



If the speed of the driven side exceeds the speed of the driving side, the freewheel clutch disengages (drive and driven) by switching from torque transmit to idle.

Application examples:

- Copier machines
- Printing machines
- Conveyor equipment
- Transport equipment (speed matching)
- Starters for combustion engines
- Ergometers
- E-bikes
- Bicycle hubs
- Starters
- Emergency power aggregates
- Generators
- Hybrid applications (E-mobility)
- Palletizing and storage systems
- Model helicopters
- Hand operated sirens
- Roller coasters
- Washing systems
- Continuous ovens
- Compressors
- Compensating gearboxes
- Gas turbine drives
- Pump drives
- Belt drives
- Wheelchairs
- etc.

GMN Freewheel Clutches Selection Table

GMN Sprag type freewheel clutches

	COMPLETE FREEWHEEL CLUTCH UNITS					BALL BEARING FREEWHEEL CLUTCH UNITS with seals		
	with seals			without seals				
GMN series	FPD	FND	RA	FP	FN	FK 2RS	FKN 2RS	FKNN 2RS
Sprags	Series 400	Series 400	Series 400	Series 400	Series 400	Series 400	Series 400	Series 400
Sprag cage	St/PA	St/PA	St/PA	St/PA	St/PA	St/PA	St/PA	St/PA
Spring	M/Z	M/Z	M/Z	M/Z	M/Z	Z	Z	Z
Ball bearings	+	+	+	+	+	+	+	+
Roller bearings	+	+	+	+	+			
Seals	+	+	+			+	+	+
Pre-lubrication	Oil	Oil	Oil			Grease	Grease	Grease
IR press fit	+			+		+		
IR key way ¹⁾		+	+		+		+	+
OR press fit	+	+		+	+	+	+	
OR keyway								+
OR mounting tab			+					
Installed width [mm]	34	34	34	27	27	12 ... 18	12 ... 18	12 ... 18
ø inner [mm]	15 ... 60	15 ... 45	15 ... 45	10 ... 60	15 ... 45	17 ... 40	17 ... 40	17 ... 40
ø outer [mm]	31 ... 78	41 ... 78	65 ... 110	26 ... 78	41 ... 78	40 ... 80	40 ... 80	40 ... 80
Operating temperature _{max} [°C]	110	110	110	170/140	170/140	110	110	110
Indexing frequency [Hz] ²⁾	60/10	60/10	60/10	60/10	60/10	10	10	10
Rotation speed n _{max} [rpm] ³⁾	2,000	1,700	1,700	10,100	4,800	3,700	3,700	3,700
Load capacity C _{dyn max} [N] ³⁾	14,128	14,128	14,128	14,128	14,128	8,902	8,902	8,902
Load capacity C _{stat max} [N] ³⁾	19,896	19,896	19,840	19,896	19,896	7,752	7,752	7,752
Torque T _{nom max} [N] ³⁾	588	588	543	588	588	267	267	267
Bearing necessary								
Hardened mating parts necessary								

Custom solutions

Customer-specific solutions can be produced on request.

	BALL BEARING FREEWHEEL CLUTCH UNITS without seals			FREEWHEEL CLUTCH INSERT ELEMENTS with rings		FREEWHEEL CLUTCH INSERT ELEMENTS without rings			GMN series
	FK	FKN	FKNN	FR	FRN	FE 400 M	FE 400 Z	FE 400 Z2	FE 8000
Series 400	Series 400	Series 400	Series 400	Series 400	Series 400	Series 400	Series 400	Series 400	Series 8000
Sprags	St/PA	St/PA	St/PA	St/PA	St/PA	St	St/PA	St/PA	St
Sprag cage	Z	Z	Z	M/Z	M/Z	M	Z	Z	Z
Spring	+	+	+						
Ball bearings									
Roller bearings									
Seals									
Pre-lubrication									
IR press fit	+			+					
IR key way ¹⁾		+	+		+				
OR press fit	+	+		+	+				
OR keyway			+						
OR mounting tab									
Installed width	12 ... 18	12 ... 18	12 ... 18	12	12	12	12	7	16 ... 25
ø inner	17 ... 40	17 ... 40	17 ... 40	10 ... 60	10 ... 45	14 ... 80	4 ... 240	2 ... 60	38 ... 220
ø outer	40 ... 80	40 ... 80	40 ... 80	26 ... 78	31 ... 78	22 ... 88	12 ... 248	10 ... 68	44 ... 236
Operat. temp. max	170/140	170/140	170/140	170/140	170/140	170	170/140	170/140	170
Indexing freq. ²⁾	10	10	10	60/10	60/10	60	10	10	5
Rot. speed max ³⁾	10,800	10,800	10,800	10,100	7,400	10,100	27,000	52,600	
Load capacity max ³⁾	8,902	8,902	8,902						
Load capacity max ³⁾	7,752	7,752	7,752						
Torque T _{max} ³⁾	267	267	267	539	539	715	2,673	277	14,060
Bearing necessary				+	+	+	+	+	+
Hardened mating parts necessary						+	+	+	+

M = meander spring · Z = tension spring · St = steel cage · PA = plastic cage
 1) key way per DIN 6885 · 2) spring specific · 3) size dependent



Internet

Our Internet website www.gmn.de contains comprehensive product information for downloading.

GMN

At its Nuremberg plant facility, GMN Paul Müller Industrie GmbH & Co. KG produces high-precision ball bearings, machine spindles, sprag type freewheel clutches and non-contact seals for a wide spectrum of applications.

Based on many years of experience in the development and production of machine components, GMN specializes in the production of high quality products in the field of freewheel clutches and is therefore in a position to offer not only an extensive standard program of freewheel-clutches but also able to accommodate customer-oriented special solutions. A world-wide GMN service network offers competent customer consultation as well as individual solutions.

GMN quality management – audited and awarded.

GMN guarantees the highest quality of products and services based on long-term reliability.

Modern development and production processes ensure products are always at the leading edge of state-of-the-art engineering. The transparent structure of all GMN company divisions and clarity of organization flows ensure customer-oriented services and economic security.

All GMN company divisions are certified to DIN ISO 9001:2008.

GMN – assuring the future.

At GMN, progress means the best possible customer support and performance optimization of technical products.

This aspiration is turned into reality at GMN, particularly by conforming to national and international environmental standards for efficient and responsible use of ecological resources.



GMN

- High Precision Ball Bearings
- Spindle Technology
- Sprag Type Freewheel Clutches
- Non Contact Seals